

ARTICLE 5 ZONING REGULATIONS

5

Article 5, Zoning Regulations provided standards for kinds and classes of buildings and use of sites and buildings within zoning districts. It addresses issues of compatibility among types of uses, scale of uses and buildings within and between different zoning districts. It is most useful to landowners, developers pursuing individual projects and public officials reviewing projects for consistency with standards and impacts on adjacent areas.

UNIFIED DEVELOPMENT CODE

ARTICLE 5 ZONING REGULATIONS

- 5.1 General Provisions
- 5.2 Rural and Agriculture Districts Standards
- 5.3 Residential Neighborhood Districts Standards
- 5.4 Commercial and Mixed-Use Districts Standards
- 5.5 Industrial Districts Standards
- 5.6 Special Purpose and Overlay Districts Standards
- 5.7 Specific Use Standards
- 5.8 Supplemental Provisions

5.1 GENERAL PROVISIONS

- 5.1.1 Purpose
- 5.1.2 Zoning Districts Established
- 5.1.3 Official Zoning Map
- 5.1.4 Districts and Uses
- 5.1.5 Residential Building and Lot Types

5.1.1 Purpose

The purpose of this Article is to:

- a. Establish districts to regulate and restrict the erection, construction, reconstruction, alteration, repair, or use of buildings, structures or land.
- b. Develop standards for various classes or kinds of buildings permitted within each district, including scale, mass and orientation to lots and streets.
- c. Develop standards to ensure the compatibility of building types and permitted uses within districts consistent with the character of the district and its particular suitability for particular uses.
- d. Develop standards to ensure the compatibility and transitions between different districts, and to ensure the compatibility and transitions with public areas and development patterns established in Article 4, Subdivision Regulations.

- e. Ensure that all standards are in accordance with the Comprehensive Plan of the City, or any official specific area plan or program adopted under the Comprehensive Plan.

5.1.2 Zoning Districts Established

The following zoning districts are established:

<i>Rural and Agriculture Districts</i>	
AG	Agricultural
AR	Agricultural Residential
RR	Rural Residential
<i>Residential Neighborhood Districts</i>	
LR	Low-density Residential
MR	Medium-density Residential
HR	High-density Residential
NR-1	Neighborhood Residential - Moderate Density
NR-2	Neighborhood Residential – Medium Density
NR-3	Neighborhood Residential – High Density
<i>Commercial and Mixed-Use districts</i>	
NB	Neighborhood Business
CB	Community Business
CBD	Central Business District
MUR	Mixed-Use Residential Emphasis
MUB	Mixed-Use Business Emphasis
MUE	Mixed-Use Employment Emphasis
BP	Business Park
<i>Industrial Districts</i>	
LI	Light Industrial
HI	Heavy Industrial
<i>Special Purpose and Overlay Districts</i>	
P	Public District
PUD	Planned Unit Development
AD	Airport District
SS	Support Services
M	Military
AHR	Airport Height and Use Restrictions
CHR	State Capitol Height Restrictions

Form-based Code Districts*	
T-1	Natural
T-2	Rural
T-3	Suburban
T-4	General Urban
T-5	Urban Center
T-6	Urban Core
D	District
CS	Civic Space

* Form-based code districts are subject to a Regulating Plan, and the procedures and district standards in Article 7. Each district may further be limited with respect to uses by L (limited), R (restricted), and O (open) based on a specific Regulating Plan.

need to work closely together in determining the appropriate category for a specific use.

Uses are allowed in various zoning districts as either “permitted by right” (P), “permitted after administrative review” (A), or “permitted after conditional discretionary review” (C), as indicated in Table 5-1. The procedures and general criteria for these reviews are included in Article 2.

5.1.3 Official Zoning Map

The boundaries of the zoning districts in the City are established as shown on a map entitled City of Cheyenne zoning map. The City of Cheyenne zoning map is on file and maintained at the office of the City Engineer. The City of Cheyenne zoning map will bear the signature of the City Engineer, and will be updated in accordance with such zoning ordinance amendments as may be enacted from time to time by the governing body. The City of Cheyenne zoning map, as amended, together with the most recently adopted edition of the FEMA flood insurance rate map, including the designation of zoning districts are incorporated in this code. Copies of the map are on file at the office of the City Clerk and development office. Any conflict among the maps shall be resolved in favor of the most recent update on file at the office of the City Engineer. Any conflicts between the FEMA flood insurance rate maps and the City or County zoning maps shall be resolved in favor of the FEMA flood insurance rate maps.

5.1.4 Districts and Uses

Uses have been grouped in general categories, wherever possible. The categories are meant to allow discretion in determining permitted uses. Some uses are more specifically listed because of anticipated impacts associated with the use which warrant special treatment with respect to which district they are allowed in or special review procedures and standards that make the use compatible with certain districts. These cannot be included in the general categories and they require the approval process as indicated. Applicants and staff will

ARTICLE 5 ZONING REGULATIONS

5.1 GENERAL PROVISIONS

TABLE 5-1: ZONING DISTRICT USES

ZONING DISTRICTS ▶	AG	AR	RR	LR	MR	HR	NR-1	NR-2	NR-3	NB	CB	CBD	LI	HI	P	MUR	MUB	MUE	BP	AD	SS	PUD	M	AHR	CHR
▼ CATEGORY OF USES / SPECIFIC USES																									
Residential Uses																									
<i>Detached Dwelling</i>	P	P	P	P	P	P	P	P	P			P				P	P					P			
<i>Semi-attached Dwelling ("Duplex")</i>				P	P	P	P	P	P			P				P	P					P			
<i>Attached Dwelling ("Townhouse")</i>					P	P		P	P			P				P	P					P			
<i>Cottage Lots</i>				C	C	C	C	P	P			P				P	P					P			
<i>Group Housing</i>				C	C	C	C	C	C	C	C	C	C	C		C	C	C				P			
<i>Dormitories</i>					C	A						P				P	P					P			
<i>Multi-dwelling Building ("Apartment")</i>					C	P		P/C	P		C					P/C	P	P				P			
<i>Live/Work</i>					C	P		C	A	P	P	P				P	P	P	C			P			
<i>Mixed-use Dwelling</i>										P	P	P				P	P	P	C			P			
<i>Accessory Dwelling</i>	A	A	A	A	A	A	A	A	A			A				A	A					P			
<i>Urban Loft Building</i>									C	P	C	C				C	P					P			
<i>Manufactured housing parks</i>		C		C	C	C																P			
Civic Uses																									
<i>Neighborhood Assembly (<350 maximum occupancy)</i>	C	C	C	C	C	C	A	A	A	A	A	P	C		C	A	A	A	C			P			
<i>Community Assembly (350 - 1000 maximum occupancy)</i>											A	A	P	C		C	A	A	A	C		P			
<i>Cemeteries</i>	A										A	A	P	C		C	A	A	A			P			
<i>Primary and secondary schools</i>	C	C	C	C	C	C	C	C	C	C	A	A	P			P	A	A	A	C		P			
<i>Educational facilities</i>												P	P			P		A	A	C		P			
<i>Community Athletic Field</i>				C	C	C	C	C	C	A	A					P	A	A	A	P		P			
<i>Developed Athletic Field or Stadium</i>												C		C		C		C	C	P		P			
Service Uses																									
<i>Service Business - Limited</i>											P	P	P				A	P	P	P		P			
<i>Service Business - General</i>											C	P	P				C	C		P		P			
<i>Assisted Living / Nursing Home</i>	C	C	C	C	C	A	C	C	C	C	C					P	P	P	P			P			
<i>Animal Care - Kennel</i>	P	C										P		P						P		P			
<i>Animal Care - Hospital / Clinic</i>	C	C									C	P	C					C				P			
<i>Family Child Care Home (FCCH)</i>	P	P	P	P	P	P	P	P	P	P	P	P					P	P	P			P			
<i>Family Child Care Center (FCCC)</i>	A	A	A	A	A	A	A	A	A	A	P	P	P				A	P	P			P			
<i>Child Care Center (CCC)</i>	A	C	A	C	C	C	C	C	C	C	P	P	P				C	P	P	P		P			
<i>Emergency Shelter</i>												P		C											
<i>Entertainment, Indoor Recreation Facility</i>				C	C	C	C	C	C	C	P	P	P			A	C	P	P	P		P			

Planned District - uses subject to a development plan
 Federal Property - No City authority over uses
 Overlay District - uses subject to base zoning district
 Overlay District - uses subject to base zoning district

P = Use permitted by right A = use permitted after administrative review C = Use permitted after conditional discretionary review
 (blank = prohibited use)

ARTICLE 5

ZONING REGULATIONS

5.1 GENERAL PROVISIONS

TABLE 5-1: ZONING DISTRICT USES

ZONING DISTRICTS ►	AG	AR	RR	LR	MR	HR	NR-1	NR-2	NR-3	NB	CB	CBD	LI	HI	P	MUR	MUB	MUE	BP	AD	SS	PUD	M	AHR	CHR
▼ CATEGORY OF USES / SPECIFIC USES																									
Services Uses (cont.)																									
<i>Entertainment, Outdoor Recreation Facility</i>	C	C	C	C	C	C	C	C	C	C	C	A	C	C	A	C	C	C	P			P			
<i>Entertainment, Venue (1000+ maximum occupancy)</i>	C	C	C								A	A	C		A		C	C	P			P			
<i>Entertainment, Amusement, Recreation—Other</i>	C	C	C								C	P	C	C	C		C	C	C			P			
<i>Lodging, Bed and Breakfast</i>	P	A	A	C	C	C	C	A	P							P	P	P				P			
<i>Lodging, Hotel / Motel</i>											P	P					P	P	P			P			
<i>Medical Care, Clinic and Office</i>											P	P	P			C	P	P	P			P			
<i>Medical Care, Hospital</i>															P			P	P			P			
<i>Mini Storage</i>					C	C					P	C	P	P		C	C	P							
<i>Storage, Yard</i>													C	P					C			P			
Employment Uses																								P	
<i>Home occupations</i>	P	P	P	P	P	P	P	P	P	P	P	P	P	P		P	P	P	P			P			
<i>Office – Limited (<3,500)</i>					C	A		C	A	P	P	P	P	P		P	P	P	P			P			
<i>Office – general (3,500 – 20K)</i>						C				C	P	P	P	P		A	P	P	P			P			
<i>Office – Major Office Complex (>20K)</i>											P	P	P	P			P	P	P			P			
Commercial Uses																									
<i>Convenience Retail / Corner Store (<2k)</i>											P	P	P	P		A	P	P	P			P			
<i>Neighborhood Retail (2K - 5K)</i>											P	P	P	P		A	P	P	P			P			
<i>General Retail (5K - 25K)</i>												P	P	P			P	A	P			P			
<i>Large-scale Retail (25K - 100K)</i>												P	P	P			P	C	P			P			
<i>Warehouse Retail (> 100K)</i>												P	P	P			P		P			P			
<i>Grocery Store <45K</i>											P	P	P	P			P	P	P			P			
<i>Supermarket > 45K</i>												P	P	P			P	C	P			P			
<i>Outdoor Sales, Limited</i>											A	P	A			A	A	A	C			P			
<i>Outdoor Sales, Seasonal</i>											C	A	C			C	C	C	C			P			
<i>Outdoor Sales, Event or Display Area</i>											C	A	C			C	C	C	C			P			
<i>Outdoor Sales</i>												C		C			C		C			P			
<i>Bars and liquor stores</i>											C	C	P		A		C	C		P		P			
<i>Automobile Service Repair</i>											C	P	C	P	P		C	C	P			P			
<i>Automobile Service Station - Limited</i>											C	P	C	P	P		C	C	P	P		P			
<i>Automobile Service Station - General</i>												P	C	P	P			C	P			P			
<i>Automobile Service Station – Large-scale</i>												C		C	P				P			P			

Planned District - uses subject to a development plan
 Federal Property - No City authority over uses
 Overlay District - uses subject to base zoning district
 Overlay District - uses subject to base zoning district

ARTICLE 5

ZONING REGULATIONS

5.1 GENERAL PROVISIONS

TABLE 5-1: ZONING DISTRICT USES

ZONING DISTRICTS ►	AG	AR	RR	LR	MR	HR	NR-1	NR-2	NR-3	NB	CB	CBD	LI	HI	P	MUR	MUB	MUE	BP	AD	SS	PUD	M	AHR	CHR
▼ CATEGORY OF USES / SPECIFIC USES																									
Commercial Uses (cont.)																									
<i>Food Service – Limited (under 2K)</i>										P	P	P				P	P	P	P	P	P				
<i>Food Service – General (2K – 4K)</i>										C	P	P					P	P	P	P	P				
<i>Food Service – Large-scale (over 4k)</i>											P	P					P	P	P			P			
Industrial Uses																									
<i>Data Center</i>										C	C	C	P	P			C	P	P						
<i>Limited Industrial</i>										A	A	P	P	P	P	A	P	P	P			P			
<i>Moderate Industrial</i>												C	P	P			C	P	P			P			
<i>General Industrial</i>													C	P						P		C			
<i>Industrial</i>														C						C		C			
<i>Limited Outdoor Storage</i>													P	P	C			A	P			C			
<i>Outdoor Storage</i>													C	P				C				C			
<i>Impoundment Yards</i>													P	P			C	C				C			
<i>Salvage yards</i>													C	C								C			
<i>Junk yards</i>														C								C			
<i>Air cargo terminals</i>																					P	C			
<i>Aircraft sales, repair, service, storage and relating uses</i>																					P	C			
<i>Railroad yards and maintenance buildings</i>													P	P					P			C			
Public Service Uses																									
<i>Commercial and Public Parking Facility</i>												P			P		P	P	P			P			
<i>Government Facility</i>										P	P	P	P	P	P	P	P	P	P	P	P	P			
<i>Military</i>																					P	P			
<i>Recycling Services</i>											C		P	P			C	C	C			P			
<i>Transportation facilities</i>											C		P	P	P					P	P	P			
<i>Utility Stations</i>	A	A	A	A	A	A	A	A	A	A	A	A	A	A	A	A	A	A	A	P	A	P			
Agriculture Uses																									
<i>General Agriculture</i>	P																				P	P			
<i>Limited Agriculture</i>	P	P																				P	P		
<i>Agricultural equipment or product sales</i>	C																					P			
<i>Commercial stables, arenas, and show barns</i>	C	C																					P		
<i>Nurseries, landscaping</i>	P	P									C		P	P			C						P		

Planned District - uses subject to a development plan
 Federal Property - No City authority over uses
 Overlay District - uses subject to base zoning district
 Overlay District - uses subject to base zoning district

ARTICLE 5

ZONING REGULATIONS

5.1 GENERAL PROVISIONS

5.1.5 Residential Building and Lot Types

The following residential lot types and building standards are enabled in the various residential zoning districts. Table 5-2 establishes the range of lot and building types enabled in each of the Residential Zoning Districts. All uses of land and buildings that are enabled by Table 5-1 shall meet the Lot and Building Type standards enabled for the particular zoning district.

a. Detached Dwelling (“Single-family”) Lot Types and Building Standards.

TYPE DD1: DETACHED DWELLING / AGRICULTURE LOT		
Lot Area (min.)		20 acres
Lot Frontage (min.)		300'
Setbacks: Principal Building (min.)	Front	25'
	Side	25'
	Rear	25'
Setbacks: Accessory Building (min.)	Front	Behind front building line
	Side	25'
	Rear	25'
Total Lot Coverage (max.)		n/a
Building Height (max.)	Principal	Up to three (3) stories
	Accessory	20' residential 50' agriculture
Zoning Districts		Permitted: AG, AR

TYPE DD2: DETACHED DWELLING / RURAL LOT		
Lot Area (min.)		5 acres
Lot Frontage (min.)		300'
Setbacks: Principal Building (min.)	Front	25'
	Side	25'
	Rear	25'
Setbacks: Accessory Building (min.)	Front	Behind front building line
	Side	25'
	Rear	25'
Total Lot Coverage (max.)		n/a
Building Height (max.)	Principal	Up to three (3) stories
	Accessory	20' residential 50' agriculture
Zoning Districts		Permitted: AR, RR

ARTICLE 5

ZONING REGULATIONS

5.1 GENERAL PROVISIONS

TYPE DD3: DETACHED DWELLING / LARGE LOT

Lot Area (min.)		1.5 acres
Lot Frontage (min.)		180'
Setbacks: Principal Building (min.)	Front	50'
	Side	50'
	Rear	50'
Setbacks: Accessory Building (min.)	Front	10' behind front building line
	Side	10' 25' on street side corner lots
	Rear	10'
Total Lot Coverage (max.)		40%
Building Height (max.)	Principal	Up to three (3) stories
	Accessory	In no case higher than the principal building
Zoning Districts	Permitted: AR, RR, LR	

The diagrams for Type DD3 show a large lot with a principal building and an accessory building. The site plan (right) and elevation (left) are annotated with letters A through H. A: Frontage; B: Front Setback; C: Rear Setback; D: Buildable Lot Area; E: Property Boundary; F: Depth; G: Public Sidewalk; H: Public Right-of-way.

TYPE DD4: DETACHED DWELLING / LOW-DENSITY LOT

Lot Area (min.)		.5 acres
Lot Frontage (min.)		100'
Setbacks: Principal Building (min.)	Front	25'
	Side	10'
	Rear	25'
Setbacks: Accessory Building (min.)	Front	10' behind front building line
	Side	10' 25' on street side corner lots
	Rear	25'
Total Lot Coverage (max.)		40%
Building Height (max.)	Principal	Up to three (3) stories
	Accessory	In no case higher than the principal building
Zoning Districts	Permitted: AR, LR, NR-1	

The diagrams for Type DD4 show a smaller lot with two principal buildings and an accessory building. The site plan (right) and elevation (left) are annotated with letters A through H. A: Frontage; B: Front Setback; C: Rear Setback; D: Buildable Lot Area; E: Property Boundary; F: Depth; G: Public Sidewalk; H: Public Right-of-way.

- | | |
|------------------------|-------------------------|
| (A) Frontage | (E) Property Boundary |
| (B) Front Setback | (F) Depth |
| (C) Rear Setback | (G) Public Sidewalk |
| (D) Buildable Lot Area | (H) Public Right-of-way |

ARTICLE 5

ZONING REGULATIONS

5.1 GENERAL PROVISIONS

TYPE DD5: DETACHED DWELLING / SUBURBAN LOT

Lot Frontage (min.)		70'
Setbacks: Principal Building (min.)	Front	25'
	Side	7.5' 10' on street side corner lots
	Rear	20'
Setbacks: Accessory Building (min.)	Front	10' behind front building line
	Side	7.5' 25' on street side corner lots
	Rear	5'
Total Lot Coverage (max.)		60%
Building Height (max.)	Principal	Up to three (3) stories
	Accessory	In no case higher than the principal building
Zoning Districts	Permitted: LR, MR, NR-1	

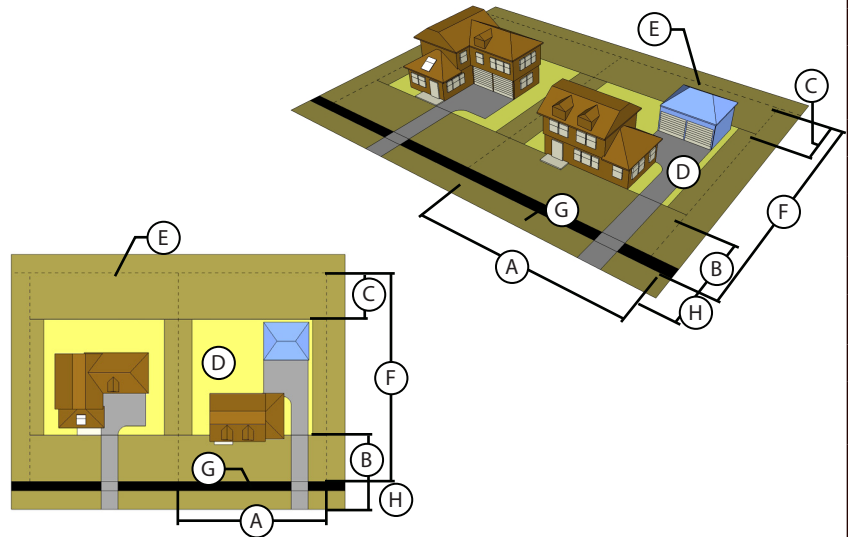

TYPE DD6: DETACHED DWELLING / STANDARD LOT

Lot Frontage (min.)		55'
Setbacks: Principal Building (min.)	Front	25'
	Side	5' 10' on street-side corner lots
	Rear	20'
Setbacks: Accessory Building (min.)	Front	10' behind front building line
	Side	5' 25' on street side corner lots
	Rear	5'
Total Lot Coverage (max.)		60%
Building Height (max.)	Principal	Up to three (3) stories
	Accessory	In no case higher than the principal building
Zoning Districts	Permitted: MR, HR, NR-1, NR-2, NR-3	

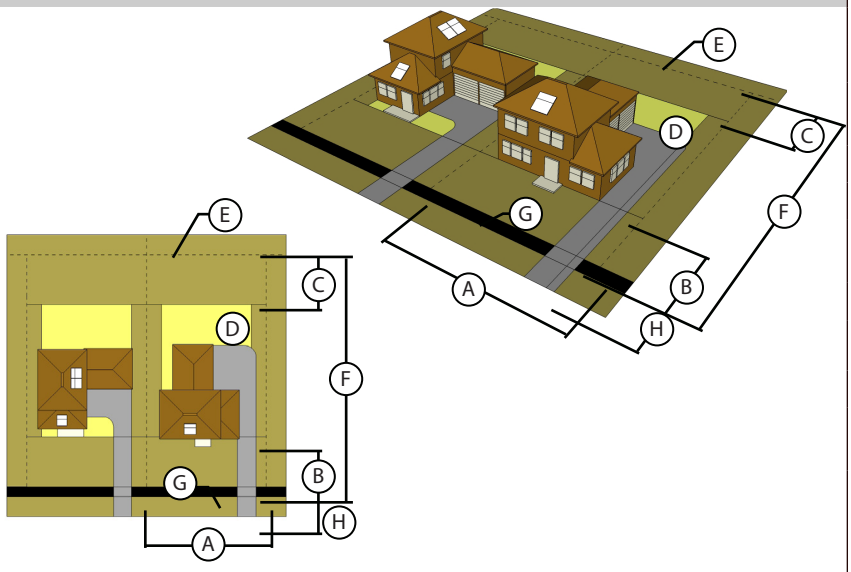

- | | |
|------------------------|-------------------------|
| (A) Frontage | (E) Property Boundary |
| (B) Front Setback | (F) Depth |
| (C) Rear Setback | (G) Public Sidewalk |
| (D) Buildable Lot Area | (H) Public Right-of-way |

ARTICLE 5 ZONING REGULATIONS

5.1 GENERAL PROVISIONS

TYPE DD7: DETACHED DWELLING / SMALL LOT

Lot Frontage (min.)		40' 45' on corner lots
Setbacks: Principal Building (min.)	Front	25'
	Side	5' 10' on street side corner lots
	Rear	20'
Setbacks: Accessory Building (min.)	Front	10' behind front building line
	Side	2', 0' if party wall [a] 15' on street side corner lots
	Rear	2' 5' if alley loaded
Total Lot Coverage (max.)		60%
Building Height (max.)	Principal	Up to three (3) stories
	Accessory	In no case higher than the principal building
Zoning Districts		Permitted: MR, HR, NR-1, NR-2, NR-3

[a] 0' setbacks on attached buildings require a party wall meeting all building code standards and proper designation on a recorded plat.

TYPE DD8: DETACHED DWELLING / URBAN LOT

Lot Frontage (min.)		30' 42' on corner lots
Setbacks: Principal Building (min.)	Front	15'
	Side	3', but at least 10' both sides combined [a] 10' on street side corner lots
	Rear	20'
Setbacks: Accessory Building (min.)	Front	10' behind front building line
	Side	2', 0' if party wall [a] 15' on street side corner lots
	Rear	2' 5' if alley loaded
Total Lot Coverage (max.)		70%
Building Height (max.)	Principal	Up to three (3) stories
	Accessory	In no case higher than the principal building
Zoning Districts		Permitted: NR-2, NR-3

[a] Setbacks of 0' are allowed for zero lot line development provided a minimum 10' separation is maintained between all principal buildings and appropriate maintenance easements and covenants are recorded with the plat.

(A) Frontage	(D) Buildable Lot Area	(G) Public Sidewalk	(J) Alley
(B) Front Setback	(E) Property Boundary	(H) Public Right-of-way	
(C) Rear Setback	(F) Depth	(I) Shared Driveway	

ARTICLE 5 ZONING REGULATIONS

5.1 GENERAL PROVISIONS

b. Semi-Attached Dwelling (“Duplex”) Lot Type and Building Standards.

TYPE SD1: SEMI-ATTACHED DWELLING / LARGE LOT		
Lot Frontage (min.)		40' 45' on corner lots
Setbacks: Principal Building (min.)	Front	Context of other adjacent detached dwellings or 25', whichever is less.
	Side	0' attached side [a] 5' detached side 10' on street side corner lots
	Rear	20'
Setbacks: Accessory Building (min.)	Front	10' behind front building line
	Side	2', 0' if party wall [a] 15' on street side corner lots
	Rear	2' 5' if alley loaded
Total Lot Coverage (max.)		60%
Building Height (max.)	Principal	Up to three (3) stories
	Accessory	In no case higher than the principal building
Zoning Districts	Permitted: LR, NR-1, MR	

[a] 0' setbacks on attached dwellings require a party wall meeting all building code standards and proper designation on a recorded plat.

(A) Frontage	(D) Accessory Building	(G) Public Sidewalk
(B) Side Setback	(E) Property Boundary	(H) Public Right-of-way
(C) Rear Setback	(F) Depth	(I) Shared Driveway

ARTICLE 5

ZONING REGULATIONS

5.1 GENERAL PROVISIONS

TYPE SD2: SEMI-ATTACHED DWELLING / STANDARD LOT		
Lot Frontage (min.)	35' 40' on corner lots	
Setbacks: Principal Building (min.)	Front	Context of other adjacent detached dwellings or 25', whichever is less.
	Side	0' attached side [a] 5' detached side 10' on street side corner lots
	Rear	20'
Setbacks: Accessory Building (min.)	Front	10' behind front building line
	Side	2', 0' if party wall [a] 15' on street side corner lots
	Rear	2' 5' if alley loaded
Total Lot Coverage (max.)	60%	
Building Height (max.)	Principal	Up to three (3) stories
	Accessory	In no case higher than the principal building
Zoning Districts	Permitted: MR, HR, NR-1, NR-2, NR-3	

[a] 0' setbacks on attached dwellings require a party wall meeting all building code standards and proper designation on a recorded plat.

(A) Frontage	(D) Accessory Building	(G) Public Sidewalk
(B) Side Setback	(E) Property Boundary	(H) Public Right-of-way
(C) Rear Setback	(F) Depth	(I) Alley

ARTICLE 5 ZONING REGULATIONS

5.1 GENERAL PROVISIONS

TYPE SD3: SEMI-ATTACHED DWELLING / SMALL LOT

Lot Frontage (min.)		30' 35' on corner lots
Setbacks: Principal Building (min.)	Front	Context of other adjacent detached dwellings or 25', whichever is less.
	Side	0' attached side [a] 5' detached side 10' on street side corner lots
	Rear	20'
Setbacks: Accessory Building (min.)	Front	10' behind front building line
	Side	2', 0' if party wall [a] 15' on street side corner lots
	Rear	2' 5' if alley loaded
Total Lot Coverage (max.)		60%
Building Height (max.)	Principal	Up to three (3) stories
	Accessory	In no case higher than the principal building
Zoning Districts	Permitted: MR, HR, NR-2, NR-3	

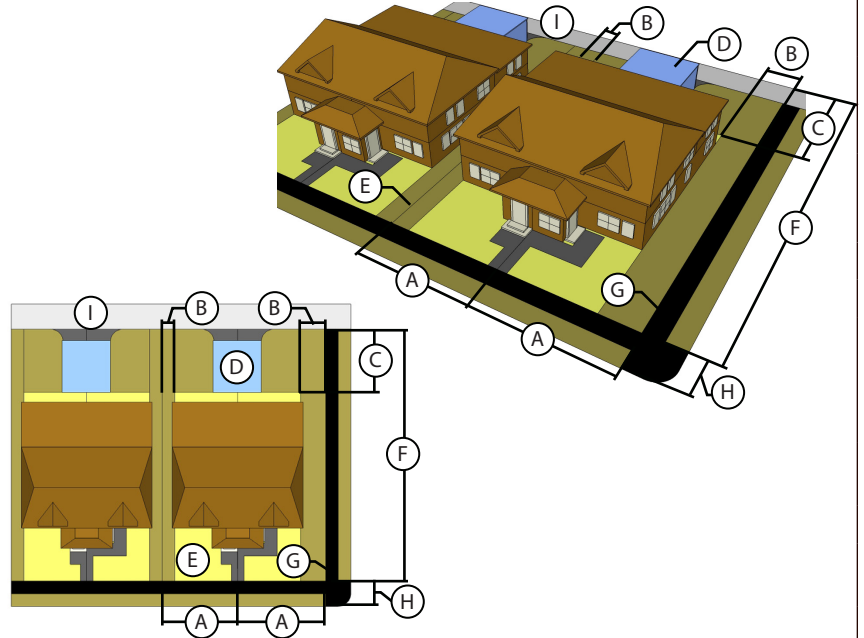

[a] 0' setbacks on attached dwellings require a party wall meeting all building code standards and proper designation on a recorded plat.

(A) Frontage	(D) Accessory Building	(G) Public Sidewalk
(B) Side Setback	(E) Buildable Lot Area	(H) Public Right-of-way
(C) Rear Setback	(F) Depth	(I) Alley

ARTICLE 5

ZONING REGULATIONS

5.1 GENERAL PROVISIONS

c. Attached Dwellings (“Townhouse”) Lot Type and Building Standards.

TYPE AD1: ATTACHED DWELLING / LARGE LOT		
Lot Frontage (min.)		25' 30' on corner lots
Setbacks: Principal Building (min.)	Front	15' – 25' [b]
	Side	0' attached side [a] 5' detached side 10' on street side corner lots
	Rear	20'
Setbacks: Accessory Building (min.)	Front	10' behind front building line
	Side	2', 0' if party wall [a] 15' on street side corner lots
	Rear	2' 5' if alley loaded
Total Lot Coverage (max.)		70%
Building Height (max.)	Principal	Up to three (3) stories
	Accessory	In no case higher than the principal building
Zoning Districts	Permitted: MR, HR, NR-2, NR-3	

[a] 0' setbacks on attached dwellings require a party wall meeting all building code standards and proper designation on a recorded plat.

[b] The front building line shall be located based on the context of any other adjacent detached dwellings, and located within 5' of the setbacks for these buildings, but no greater than 30'.

(A) Frontage	(D) Property Boundary	(G) Buildable Lot Area
(B) Front Setback	(E) Depth	(H) Alley
(C) Accessory Building	(F) Public Sidewalk	

ARTICLE 5 ZONING REGULATIONS

5.1 GENERAL PROVISIONS

TYPE AD2: ATTACHED DWELLING / STANDARD LOT		
Lot Frontage (min.)		20' 25' on corner lots
Setbacks: Principal Building (min.)	<i>Front</i>	10' – 20' [b]
	<i>Side</i>	0' attached side [a] 5' detached side 10' on street side corner lots
	<i>Rear</i>	20' 5' if alley loaded
Setbacks: Accessory Building (min.)	<i>Front</i>	10' behind front building line
	<i>Side</i>	2' 0' if party wall [a] 10' on street side corner lots
	<i>Rear</i>	2' 5' if alley loaded
Total Lot Coverage (max.)		70%
Building Height (max.)	<i>Principal</i>	Up to three (3) stories
	<i>Accessory</i>	In no case higher than the principal building
Zoning Districts		Permitted: HR, NR-2, NR-3

- [a] 0' setbacks on attached dwellings require a party wall meeting all building code standards and proper designation on a recorded plat.
 [b] The front building line shall be located based on the context of any other adjacent detached dwellings, and located within 5' of the setbacks for these buildings, but no greater than 25'.

(A) Frontage	(D) Property Boundary	(G) Buildable Lot Area
(B) Front Setback	(E) Depth	(H) Alley
(C) Accessory Building	(F) Public Sidewalk	

ARTICLE 5

ZONING REGULATIONS

5.1 GENERAL PROVISIONS

TYPE AD3: ATTACHED DWELLING / SMALL LOT		
Lot Frontage (min.)		16' 24' on end units or corner lots
Setbacks: Principal Building (min.)	Front	10' – 20' [b]
	Side	0' attached side [a] 5' detached side 10' on street side corner lots
	Rear	20' 5' if alley loaded
Setbacks: Accessory Building (min.)	Front	10' behind front building line
	Side	2' 0' if party wall [a] 10' on street side corner lots
	Rear	2' 5' if alley loaded
Total Lot Coverage (max.)		85%
Building Height (max.)	Principal	Up to three (3) stories
	Accessory	In no case higher than the principal building
Zoning Districts		Permitted: NR-3 Conditional: NR-2

- [a] 0' setbacks on attached dwellings require a party wall meeting all building code standards and proper designation on a recorded plat.
- [b] The front building line shall be located based on the context of any other adjacent detached dwellings, and located within 5' of the setbacks for these buildings, but no greater than 25'.

(A) Frontage	(D) Property Boundary	(G) Buildable Lot Area
(B) Front Setback	(E) Depth	(H) Alley
(C) Accessory Building	(F) Public Sidewalk	

ARTICLE 5 ZONING REGULATIONS

5.1 GENERAL PROVISIONS

d. Multi-dwelling Buildings (“Apartment”) Lot Type and Building Standards.

TYPE MD1: MULTI-DWELLING BUILDING / LARGE LOT		
Lot Area (min.)	20,000 square feet	
Lot Frontage (min.)	150'	
Setbacks: Principal Building (min.)	Front	30'
	Side	15' 30' on street side corner lots
	Rear	30'
Setbacks: Accessory Building (min.)	Front	10' behind front building line
	Side	15' 30' on street side corner lots
	Rear	10'
Total Lot Coverage (max.)	80%	
Building Height	Principal	2 to 3 stories Up to 5 stories with conditional review
	Accessory	Up to 2 stories
Zoning Districts	Permitted: NR-3 Conditional: MR, HR, NR-2	

- | | | |
|-------------------|------------------------|------------------------|
| (A) Frontage | (D) Accessory Building | (G) Public Sidewalk |
| (B) Front Setback | (E) Property Boundary | (H) Buildable Lot Area |
| (C) Rear Setback | (F) Depth | |

ARTICLE 5

ZONING REGULATIONS

5.1 GENERAL PROVISIONS

TYPE MD2: MULTI-DWELLING BUILDING / STANDARD LOT		
<i>Lot Area</i>		9,000 – 19,999 square feet
<i>Lot Frontage</i>		80' – 150'
<i>Setbacks: Principal Building (min.)</i>	<i>Front</i>	10' – 20'
	<i>Side</i>	5' 15' on street side corner lots
	<i>Rear</i>	15' 5' if alley loaded
<i>Setbacks: Accessory Building (min.)</i>	<i>Front</i>	10' behind front building line
	<i>Side</i>	5' 15' on street side corner lots
	<i>Rear</i>	2' 5' if alley loaded
<i>Total Lot Coverage (max.)</i>		80%
<i>Building Height</i>	<i>Principal</i>	2 to 3 stories Up to 5 stories with conditional review
	<i>Accessory</i>	Up to 2 stories
<i>Zoning Districts</i>	Permitted: HR, NR-3, NR-2 Conditional: MR	

- | | | |
|-----------------------|------------------------|-----------|
| (A) Frontage | (D) Depth | (G) Alley |
| (B) Front Setback | (E) Public Sidewalk | |
| (C) Property Boundary | (F) Buildable Lot Area | |

ARTICLE 5

ZONING REGULATIONS

5.1 GENERAL PROVISIONS

TYPE MD3: MULTI-DWELLING BUILDING / SMALL LOT

<i>Lot Area</i>		≤ 8,999 square feet
<i>Lot Frontage</i>		50' – 80'
<i>Setbacks: Principal Building (min.)</i>	<i>Front</i>	10' – 20'
	<i>Side</i>	5' 15' on street side corner lots
	<i>Rear</i>	15' 5' if alley loaded
<i>Setbacks: Accessory Building (min.)</i>	<i>Front</i>	10' behind front building line
	<i>Side</i>	5' 15' on street side corner lots
	<i>Rear</i>	2' 5' if alley loaded
<i>Total Lot Coverage (max.)</i>		80%
<i>Building Height</i>	<i>Principal</i>	2 to 3 stories Up to 5 stories with conditional review
	<i>Accessory</i>	Up to 2 stories
<i>Zoning Districts</i>	Permitted: HR, NR-2, NR-3 Conditional: MR	

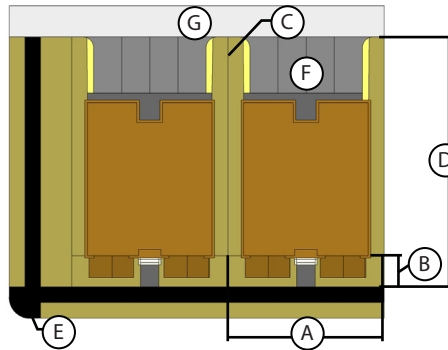
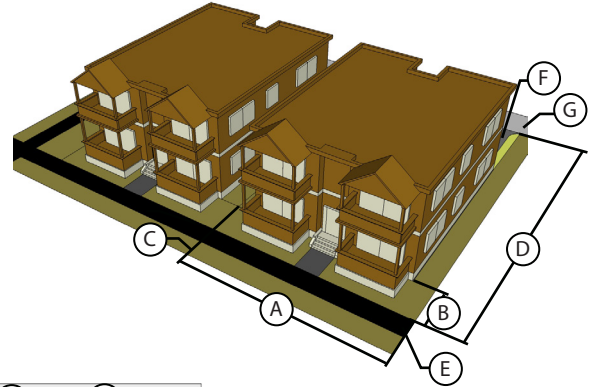

- | | | |
|-----------------------|------------------------|-----------|
| (A) Frontage | (D) Depth | (G) Alley |
| (B) Front Setback | (E) Public Sidewalk | |
| (C) Property Boundary | (F) Buildable Lot Area | |

- e. **Residential Zoning Districts and Lot and Building Types.** Table 5-2 establishes the lot and building types allowed for each residential zoning district.

TABLE 5-2: SUMMARY OF RESIDENTIAL ZONING DISTRICTS AND LOT AND BUILDING TYPES

Lot Type Zoning District	Detached Dwelling Lots								Semi-Attached Dwelling Lots ("Duplex")			Attached Dwelling Lots ("Townhouse")			Multi-dwelling Lots ("Apartments")		
	Ag. DD1	Rural DD2	Large DD3	Low-den DD4	Suburban DD5	Standard DD6	Small DD7	Urban DD8	Large SD1	Standard SD2	Small SD3	Large AD1	Standard AD2	Small AD3	Large MD1	Standard MD2	Small MD3
AG	P																
AR	P	P	P														
RR		P	P														
LR			P	P	P			P									
MR					P	P		P	P	P	P	P		C	C	C	C
HR						P		P	P	P	P	P	P	C	P	P	P
NR-1				P	P	P		P	P								
NR-2						P	P	P	P	P	P	P	P	C	C	P	P
NR-3						P	P	P	P	P	P	P	P	P	P	P	P

Key: P = Permitted by right subject to general district standards
 C = Permitted subject to discretionary conditional review process

5.2 RURAL AND AGRICULTURE DISTRICTS STANDARDS

- 5.2.1 AG – Agriculture District
- 5.2.2 AR – Agriculture Residential District
- 5.2.3 RR – Rural Residential District

5.2.1 AG – Agriculture District

- a. **Intent.** The AG District is intended for agriculture uses or other use of lands in a natural state. Agriculture-related residential uses and agriculture-related businesses are included provided they support the primary use of the land for farming, ranching, or agriculture uses. All uses require little or no public infrastructure in the short term, or rural level standards in the interim or long term. The regulations are designed to protect agriculture uses in the City and the open rural character of the districts by prohibiting the establishment of scattered business, industrial, and other uses that are unrelated to the predominantly agricultural character or any general plan of development and that might inhibit the best future urban utilization of the land.
- b. **Applicability.** The AG District is applicable to any areas where significant natural lands or open spaces are to be protected, and specifically the Agriculture/Rural or Rural Residential Category in the Cheyenne Comprehensive Plan.
- c. **Context.** The Agriculture District is also applicable as an interim or holding zone for areas that may be further developed, re-subdivided and reclassified in the long term, but where minimal development activity in the interim is acceptable and will not prematurely establish a development pattern through infrastructure investments, street networks, or smaller lot patterns. Less connected street networks and rural street cross sections are appropriate to support lots in this district.
- d. **Eligible Lot and Building Types.** The following lot types, building types and dimensions specified in Table 5-2 are permitted in the AG district:
 - 1. Agriculture Lot / Detached Dwelling (Type DD1), with well and septic subject to State Department of Environmental Quality Standards and the City/County Health Department Standards.
- e. **Permitted Uses.** The uses permitted in the AG district are specified in Table 5-1 as either “permitted” or “administrative” or “conditional.”

5.2.2 AR – Agriculture Residential District

- a. **Intent.** The AR District is intended for agriculture and residential uses on large lots that typify a rural lifestyle. All uses require little or no public infrastructure in the short term, or rural level standards in the interim or long term. The regulations are designed to protect the essentially open rural character of the districts and enable a range of accessory agriculture uses in association with rural living.
- b. **Applicability.** The AR District is applicable to any areas where very low-density residential and limited agriculture uses are acceptable as the long-range development pattern, and specifically the Rural Residential Category in the Cheyenne Comprehensive Plan. It is also acceptable in limited application in the Urban Transition Category.
- c. **Context.** This district is also appropriate as a base zoning in conjunction with Rural Cluster development patterns that can better and permanently preserve greater amounts of contiguous open space in conjunction with low-density residential development. Less connected street networks and rural street cross sections are appropriate to support lots in this district.
- d. **Eligible Lot and Building Types.** The following lot types, building types and dimensions specified in Table 5-2 are permitted in the AR district:
 - 1. Agriculture Lot / Detached Dwelling (Type DD1), with well and septic subject to State Department of Environmental Quality Standards.
 - 2. Rural Lot / Detached Dwelling (Type DD2), with well and septic subject to State Department of Environmental Quality Standards.
 - 3. Large Lot / Detached Dwelling (Type DD3), only if property is served by an approved central water distribution system or sewer collection treatment system, subject to a recommendation for approval from the State Department of Environmental Quality.
 - 4. Low-density Lot / Detached Dwelling (Type DD4), if property is served by an approved central water distribution system and sewer collection treatment system, subject to a recommendation for approval from the State Department of Environmental Quality.
- e. **Permitted Uses.** The uses permitted in the AR district are specified in Table 5-1 as either “permitted” or “administrative” or “conditional.”

5.2.3 RR Rural Residential District

- a. **Intent.** The RR District is intended for residential uses on large lots that typify a semi-rural lifestyle. All uses require little or no public infrastructure in the short term, or rural level standards in the interim or long term. The regulations are designed to protect the essentially open rural character of the districts and protect the primarily residential use of land.
- b. **Applicability.** The RR District is applicable to any areas where very low-density residential and are acceptable as the long-range development pattern, and specifically the Rural Residential Category in the Cheyenne Comprehensive Plan. It is also acceptable in limited application in the Urban Transition Category.
- c. **Context.** Large uninterrupted applications of this district without transitions to either higher densities or more rural open spaces should be avoided so that significant populated areas that must rely solely on automobile travel and which are remote from necessary municipal services are not created. This district is also appropriate as a base zoning in conjunction with the Open Space Design Option that can better and permanently preserve greater amounts of contiguous open space in conjunction with low-density residential development. Less connected street networks and rural street cross sections are appropriate to support lots in this district.
- d. **Eligible Lot and Building Types.** The following lot types, building types and dimensions specified in Table 5-2 are permitted in the RR district:
 - 1. Rural Lot / Detached Dwelling (Type DD2)
 - 2. Large Lot / Detached Dwelling (Type DD3)
- e. **Permitted Uses.** The uses permitted in the RR district are specified in Table 5-1 as either "permitted" or "administrative" or "conditional."

5.3 RESIDENTIAL NEIGHBORHOOD DISTRICTS STANDARDS

- 5.3.1 LR – Low-density Residential District
- 5.3.2 Reserved
- 5.3.3 MR – Medium-density Residential District
- 5.3.4 Reserved
- 5.3.5 HR – High-density Residential District
- 5.3.6 Reserved
- 5.3.7 NR-1 – Neighborhood Residential – Moderate Density
- 5.3.8 NR-2 – Neighborhood Residential – Medium Density
- 5.3.9 NR-3 – Neighborhood Residential – High Density

5.3.1 LR Low-density Residential District

- a. **Intent.** The LR District is intended for a mix of lower density dwellings. All uses require full access to public infrastructure and city services. The regulations are designed to protect the neighborhood character of the district and protect the primarily residential use of land.
- b. **Applicability.** The LR District is applicable to areas where suburban development patterns are desired, and specifically the Urban Transition Residential Category in the Cheyenne Comprehensive Plan.
- c. **Context.** Typically this district should be used only in areas that are no more than 1 mile from any existing or planned Activity Center. Large uninterrupted applications of this district without transitions to either higher densities and activity centers or to more rural open spaces should be avoided so that significant populated areas that must rely solely on automobile travel and which are remote from necessary municipal services are not created.
- d. **Eligible Lot and Building Types.** The following lot types, building types and dimensions specified in Table 5-2 are permitted in the LR District:
 - 1. Large Lot / Detached Dwelling (Type DD3)
 - 2. Low-density Lot / Detached Dwelling (Type DD4)
 - 3. Suburban Lot / Detached Dwelling (Type DD5)
 - 4. Large Lot / Semi-attached Dwelling (Type SD1)

- e. **Permitted Uses.** The uses permitted in the LR District are specified in Table 5-1 as either “permitted” or “administrative” or “conditional.”
- f. **Site and Building Design Standards.** To create neighborhood character and visual diversity for housing options, the General Residential Design Standards in Section 6.6 and access standards in Section 4.3 shall apply in the LR Zoning District.

5.3.2 [RESERVED]

Previously, this section contained LR-2 District regulations, which were discontinued. Please use LR District regulations.

5.3.3 MR Medium-density Residential District

- a. **Intent.** The MR District is intended for a mix of density and dwelling types within a neighborhood. All uses require full access to public infrastructure and city services. The regulations are designed to protect the neighborhood character of the district and protect the primarily residential use of land.
- b. **Applicability.** The MR District is applicable to areas where more compact neighborhood development patterns are desired, and specifically the Urban Residential Category in the Cheyenne Comprehensive Plan.
- c. **Context.** Typically this district should be used only in areas that are no more than ½ mile from any existing or planned Activity Center. Large uninterrupted applications of this district without transitions to activity centers should be avoided so that significant populated areas that must rely solely on automobile travel and which are remote from necessary municipal services are not created. This district should be supported by a highly connected street network with street design types that have low design speeds and residential character streetscapes.
- d. **Eligible Lot and Building Types.** The following lot types, building types and dimensions specified in Table 5-2 are permitted in the MR District:
 - 1. Suburban Lot / Detached Dwelling (Type DD5)
 - 2. Standard Lot / Detached Dwelling (Type DD6)
 - 3. Small Lot / Detached Dwelling (Type DD7)
 - 4. Standard Lot / Semi-attached Dwelling (Type SD2)

- 5. Small Lot / Semi-attached Dwelling (Type SD3)
- 6. Large Lot / Attached Dwelling (Type AD1)
- 7. Small Lot / Multi-dwelling Building (Type MD3) – as conditional approval
- 8. Standard Lot / Multi-dwelling Building (Type MD2) – as conditional approval
- 9. Large Lot / Multi-dwelling Building (Type MD1) – as conditional approval

- e. **Permitted Uses.** The uses permitted in the MR District are specified in Table 5-1 as either “permitted” or “administrative” or “conditional.”

- f. **Site and Building Design Standards.** To create neighborhood character and visual diversity for housing options, the General Residential Design Standards in Section 6.6 and access standards in Section 4.3 shall apply in the MR Zoning District.

5.3.4 [RESERVED]

Previously, this section contained MR-2 District regulations, which were discontinued. Please use MR District regulations.

5.3.5 HR High-density Residential District

- a. **Intent.** The HR District is intended for a range of higher density, urban residential lots and building types within a neighborhood. All uses require full access to public infrastructure and city services. The regulations are designed to protect the urban character of the district and protect the primarily residential use of land.
- b. **Applicability.** The HR District is applicable to areas where more compact neighborhood development patterns are desired, and specifically the Urban Residential Category in the Cheyenne Comprehensive Plan.
- c. **Context.** Typically this district should be used only in areas that are no more than ¼ mile or up to 4 blocks from any existing or planned Activity Center. Isolated applications of this district without adjacency to activity centers should be avoided so that significant concentrations of density do not exist without convenient access to supporting and compatible non-residential uses and quality urban amenities. This district should be supported by a highly connected street network with street design types that have a high degree of pedestrian amenities.

- d. **Eligible Lot and Building Types.** The following lot types, building types and dimensions specified in Table 5-2 are permitted in the HR District:
1. Standard Lot / Detached Dwelling (Type DD6)
 2. Small Lot / Detached Dwelling (Type DD7)
 3. Standard Lot / Semi-attached Dwelling (Type SD2)
 4. Small Lot / Semi-attached Dwelling (Type SD3)
 5. Large Lot / Attached Dwelling (Type AD1)
 6. Standard Lot / Attached Dwelling (Type AD2)
 7. Small Lot / Multi-dwelling Building (Type MD3)
 8. Standard Lot / Multi-dwelling Building (Type MD2)
 9. Large Lot / Multi-dwelling Building (Type MD1)
 10. Live / Work Building (Type NB1) – as administrative approval, subject to NB district standards for this building and lot type and Section 5.7.7
- e. **Permitted Uses.** The uses permitted in the HR District are specified in Table 5-1 as either “permitted” or “administrative” or “conditional.”
- f. **Site and Building Design Standards.** Due to the more compact development pattern, range of smaller lot types, and the close relationship of the smaller lots to the public streetscape, the Residential Design Standards in Section 6.6 and access standards in Section 4.3 shall apply in the HR Zoning District.

5.3.6 [RESERVED]

Previously, this section contained HR-2 District regulations, which were discontinued. Please use HR District regulations.

5.3.7 NR-1 Neighborhood Residential – Moderate Density District

- a. **Intent.** The NR-1 District is intended for a mix of moderate-density, detached and semi-attached dwellings on a variety of lot types that promote a consistent neighborhood character. All uses require full access to public infrastructure and city services. The regulations are designed to protect the neighborhood character of the district and protect the primarily residential use of land. The overall density of this district should be between 5 and 12 dwelling units per acre.
- b. **Applicability.** The NR-1 District is applicable to areas where more compact neighborhood development patterns are desired, and specifically the Urban Residential Category in

the Cheyenne Comprehensive Plan.

- c. **Context.** Typically this district should be used only in areas that are no more than ½ mile from any existing or planned Activity Center. Large uninterrupted applications of this district without transitions to activity centers should be avoided so that significant populated areas that must rely solely on automobile travel and which are remote from necessary municipal services are not created. This district should be supported by a highly connected street network with street design types that have low design speeds and residential character streetscapes.
- d. **Eligible Lot and Building Types.** The following lot types, building types and dimensions specified in Table 5-2 are permitted in the NR-1 District:
1. Low-density Lot / Detached Dwelling (Type DD4)
 2. Suburban Lot / Detached Dwelling (Type DD5)
 3. Standard Lot / Detached Dwelling (Type DD6)
 4. Small Lot / Detached Dwelling (Type DD7)
 5. Large Lot / Semi-attached Dwelling (Type SD1)
 6. Standard Lot / Semi-attached Dwelling (Type SD2)
- e. **Permitted Uses.** The uses permitted in the NR-1 District are specified in Table 5-1 as either “permitted” or “administrative” or “conditional.”
- f. **Site and Building Design Standards.** Due to the more compact development pattern, range of smaller lot types, and the close relationship of the smaller lots to the public streetscape, the Residential Design Standards in Section 6.6 and access standards in Section 4.3 shall apply in the NR-1 Zoning District.

5.3.8 NR-2 Neighborhood Residential – Medium Density District

- a. **Intent.** The NR-2 District is intended for a medium density and mix of dwelling types that promote a consistent neighborhood character. All uses require full access to public infrastructure and city services. The regulations are designed to protect the neighborhood character of the district and protect the primarily residential use of land. The overall density of this district should be between 10 and 18 dwelling units per acre.
- b. **Applicability.** The NR-2 District is applicable to areas where more compact neighborhood development patterns are

desired, and specifically the Urban Residential Category in the Cheyenne Comprehensive Plan.

- c. **Context.** Typically this district should be used only in areas that are no more than ½ mile from any existing or planned Activity Center. Large uninterrupted applications of this district without transitions to activity centers should be avoided so that significant populated areas that must rely solely on automobile travel and which are remote from necessary municipal services are not created. This district should be supported by a highly connected street network with street design types that have low design speeds and residential character streetscapes.
- d. **Eligible Lot and Building Types.** The following lot types, building types and dimensions specified in Table 5-2 are permitted in the NR-2 District:
1. Standard Lot / Detached Dwelling (Type DD6)
 2. Small Lot / Detached Dwelling (Type DD7)
 3. Urban Lot / Detached Dwelling (Type DD8)
 4. Standard Lot / Semi-attached Dwelling (Type SD2)
 5. Small Lot / Detached Dwelling (Type SD3)
 6. Large Lot / Attached Dwelling (Type AD1)
 7. Standard Lot / Attached Dwelling (Type AD2)
 8. Small Lot / Attached Dwelling (Type AD3) – as conditional approval.
 9. Small Lot / Multi-dwelling Building (Type MD3)
 10. Standard Lot / Multi-dwelling Building (Type MD2)
 11. Large Lot / Multi-dwelling Building (Type MD1) – as conditional approval,
 12. Live / Work Building (Type NB1) – as conditional approval, subject to NB district standards for this building and lot type and Section 5.7.7.
- e. **Permitted Uses.** The uses permitted in the NR-2 District are specified in Table 5-1 as either “permitted” or “administrative” or “conditional.”
- f. **Site and Building Design Standards.** Due to the more compact development pattern, range of smaller lot types, and the close relationship of the smaller lots to the public streetscape, the Residential Design Standards in Section 6.6 and access standards in Section 4.3 shall apply in the NR-2 Zoning District.

5.3.9 NR-3 Neighborhood Residential – High Density District

- a. **Intent.** The NR-3 District is intended primarily for high-density, urban residential uses with consistent neighborhood character. All uses require full access to public infrastructure and city services. The regulations are designed to protect the neighborhood character of the district and protect the primarily residential use of land. The overall density of this district should be more than 15 dwelling units per acre.
- b. **Applicability.** The NR-3 District is applicable to areas where more compact neighborhood development patterns are desired, and specifically the Urban Residential Category in the Cheyenne Comprehensive Plan.
- c. **Context.** Typically this district should be used only in areas that are no more than ¼ mile or up to 4 blocks from any existing or planned Activity Center. Isolated applications of this district without adjacency to activity centers should be avoided so that significant concentrations of density do not exist without walking access to non-residential uses and quality urban amenities. This district should be supported by a highly connected street network with street design types that have a high degree of pedestrian amenities.
- d. **Eligible Lot and Building Types.** The following lot types, building types and dimensions specified in Table 5-2 are permitted in the NR-3 District:
1. Standard Lot / Detached Dwelling (Type DD6)
 2. Small Lot / Detached Dwelling (Type DD7)
 3. Urban Lot / Detached Dwelling (Type DD8)
 4. Standard Lot / Semi-attached Dwelling (Type SD2)
 5. Small Lot / Detached Dwelling (Type SD3)
 6. Large Lot / Attached Dwelling (Type AD1)
 7. Standard Lot / Attached Dwelling (Type AD2)
 8. Small Lot / Attached Dwelling (Type AD3)
 9. Small Lot / Multi-dwelling Building (Type MD3)
 10. Standard Lot / Multi-dwelling Building (Type MD2)
 11. Large Lot / Multi-dwelling Building (Type MD1)
 12. Live / Work (Type NB1) – as administrative approval subject to the NB district standards for this building and lot type and Section 5.7.7.
 13. Urban Loft (Type NB3) – as conditional approval

- e. **Permitted Uses.** The uses permitted in the NR-3 District are specified in Table 5-1 as either “permitted” or “administrative” or “conditional.”
- f. **Site and Building Design Standards.** Due to the more compact development pattern, range of smaller lot types, and the close relationship of the smaller lots to the public streetscape, the Residential Design Standards in Section 6.6 and access standards in Section 4.3 shall apply in the NR-3 Zoning District. Due to the nature of the urban loft lot type, the mixed use and small scale commercial design standards in Section 6.7 shall apply for this lot type in the NR-3 District.

5.4 Commercial and Mixed-use Districts Standards

- 5.4.1 NB – Neighborhood Business District
- 5.4.2 CB – Community Business District
- 5.4.3 CBD – Central Business District
- 5.4.4 MUR – Mixed-Use Residential District
- 5.4.5 MUB – Mixed-Use Business District
- 5.4.6 MUE – Mixed-Use Employment District
- 5.4.7 BP – Business Park

5.4.1 NB – Neighborhood Business District

- a. **Intent.** The NB District is intended for Retail, Employment, Service and Civic uses to support adjacent residential neighborhoods in meeting most of the daily needs of residents within close proximity to dwellings. The district should feature businesses that typically serve a target market area of ½ to 1 mile for the majority of its on-site business. Small-scale uses developed in a more compact and pedestrian oriented format allow these uses to exist compatibly and well-connected to neighborhoods, with suitable and well designed transitions. The district regulations are designed to promote small-scale business uses tightly integrated with surrounding residential uses.
- b. **Applicability.** The NB District is applicable to any area where small-scale retail and services are desired to support adjacent residential uses, specifically the Neighborhood Business Centers and smaller Mixed-use Commercial Activity Centers in the Comprehensive Plan.
- c. **Context.** The total area of the district typically entails no more than 5 to 20 acres (2 to 8 blocks) in its entirety, without transitioning to the adjacent and supportive uses and zoning districts (individual applications may be smaller). The district should include between 10,000 to 125,000 total square feet of Retail uses for the entirety of the district, with the larger end of this range justified where planned or existing residential densities are higher. The district should be located at least ½ mile from other similar districts or activity centers, unless high residential densities support more frequent location of neighborhood activity centers. The NB district requires a highly connected transportation network within the district and surrounding areas, with smaller blocks and pedestrian-oriented streetscapes on the primary streets.

ARTICLE 5 ZONING REGULATIONS

5.4 COMMERCIAL AND MIXED-USE DISTRICTS STANDARDS

d. **Lot and Building Standards.** The following lot types, building types and dimensions specified in the tables are permitted in the NB district:

TYPE NB1: LIVE / WORK		
Lot Area	1,200 – 5,000 square feet	
Lot Frontage	16' – 40' 24' – 50' on end units or corner lots	
Setbacks:	Front	0' to 20'
	Side	0' if party wall[a] or corner lots 5' in all other cases
	Rear	15' 5' if alley loaded
Building Height	2 to 3 stories Up to 3.5 stories as conditional review	
Total Lot Coverage (max.)	80%	

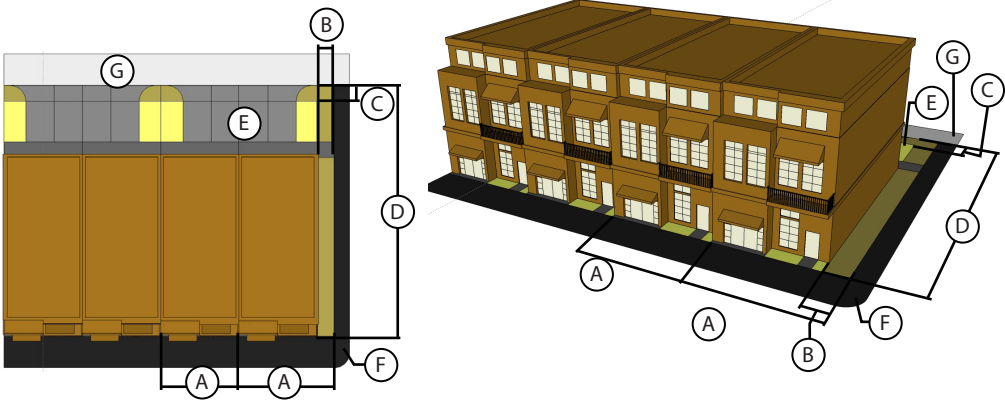

[a] 0' setbacks on attached buildings require a party wall meeting all building code standards and proper designation on a recorded plat.

TYPE NB2: MIXED-USE BUILDING		
Lot Area	2,000 – 20,000 square feet, or up to ¼ of a block, whichever is greater	
Lot Frontage	25' – 150'	
Setbacks:	Front	0' to 20'
	Side	0' if party wall[a] or corner lots 5' in all other cases
	Rear	15' 5' if alley loaded
Building Height	2 to 3 stories Up to 3.5 stories as conditional review	
Total Lot Coverage (max.)	90%	

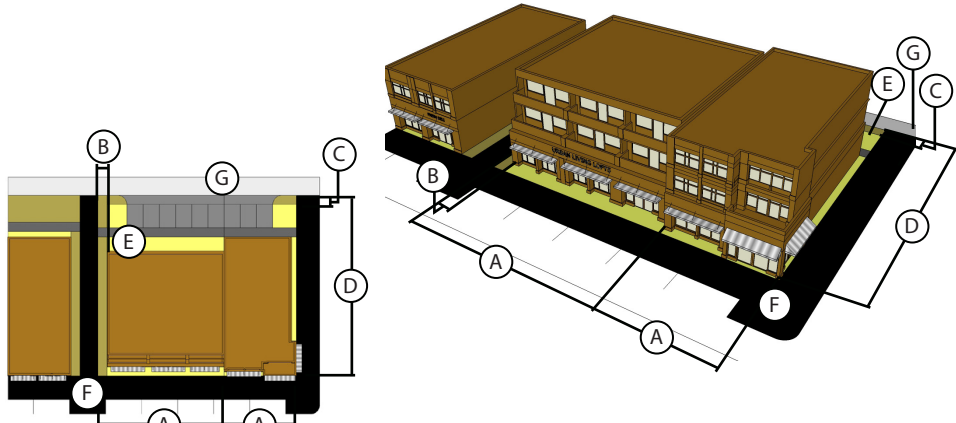

[a] 0' setbacks on attached buildings require a party wall meeting all building code standards and proper designation on a recorded plat.

- | | | |
|------------------|------------------------|-----------|
| (A) Frontage | (D) Depth | (G) Alley |
| (B) Side Setback | (E) Buildable Lot Area | |
| (C) Rear Setback | (F) Public Sidewalk | |

ARTICLE 5 ZONING REGULATIONS

5.4 COMMERCIAL AND MIXED-USE DISTRICTS STANDARDS

TYPE NB3: URBAN LOFT BUILDING		
Lot Area	2,000 square feet or up to ½ of a block, whichever is greater	
Lot Frontage	25' – 200'	
Setbacks:	Front	0' to 20'
	Side	0' if party wall[a] or corner lots, 5' in all other cases
	Rear	15', 5' if alley loaded
Building Height	2 to 6 stories	
Total Lot Coverage (max.)	90%	

[a] 0' setbacks on attached buildings require a party wall meeting all building code standards and proper designation on a recorded plat.

TYPE NB4: COMMERCIAL BUILDING / SMALL LOT		
Lot Area	2,000 – 7,999 square feet	
Lot Frontage	25' – 80'	
Setbacks:	Front	0' to 10'
	Side	0' if party wall[a] or corner lots 5' in all other cases
	Rear	15' 5' if alley loaded
Building Height	1 to 2 stories Up to 3 stories as conditional review	
Total Lot Coverage (max.)	90%	

[a] 0' setbacks on attached buildings require a party wall meeting all building code standards and proper designation on a recorded plat.

(A) Frontage	(D) Depth	(G) Alley
(B) Side Setback	(E) Buildable Lot Area	
(C) Rear Setback	(F) Public Sidewalk	

ARTICLE 5 ZONING REGULATIONS

5.4 COMMERCIAL AND MIXED-USE DISTRICTS STANDARDS

TYPE NB5: COMMERCIAL BUILDING / LARGE LOT

Lot Area	8,000 - 60,000 square feet, or up to ¼ of a block, whichever is greater	
Lot Frontage	80' - 400'	
Setbacks:	Front	0' to 10' Greater than 10' by conditional review
	Side	0' if party wall [a]; 10' in all other cases
	Rear	15' 5' if alley loaded
Building Height	1 to 2 stories Up to 3 stories as conditional review	
Total Lot Coverage (max.)	70%	

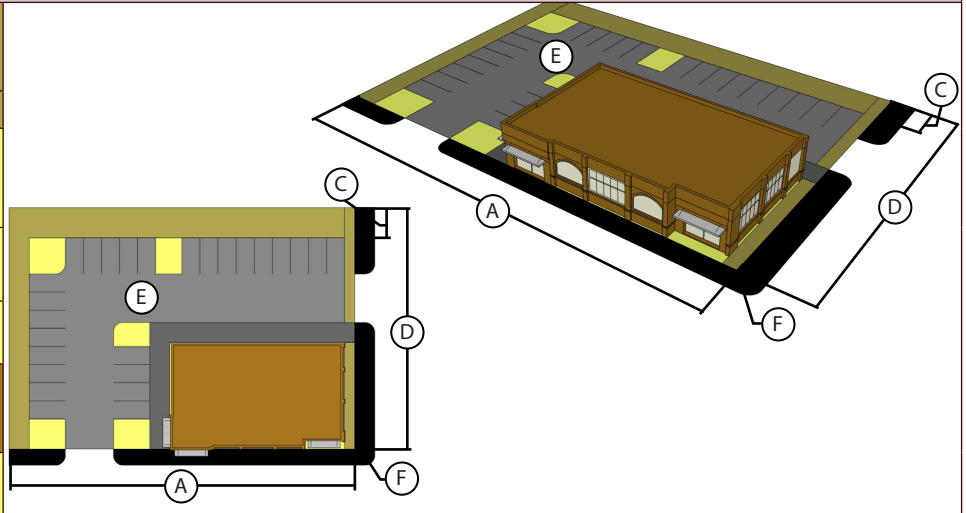

[a] 0' setbacks on attached buildings require a party wall meeting all building code standards and proper designation on the recorded plat.

TYPE NB6: SMALL CIVIC BUILDING

Lot Area	2,000 - 12,500 square feet	
Lot Frontage	25' - 100'	
Setbacks:	Front	10' to 35"
	Side	10% of lot frontage on each side, up to 10' maximum required setback
	Rear	15' 5' if alley loaded
Building Height	1 to 2.5 stories Up to 3.5 stories as conditional review	
Total Lot Coverage (max.)	70%	

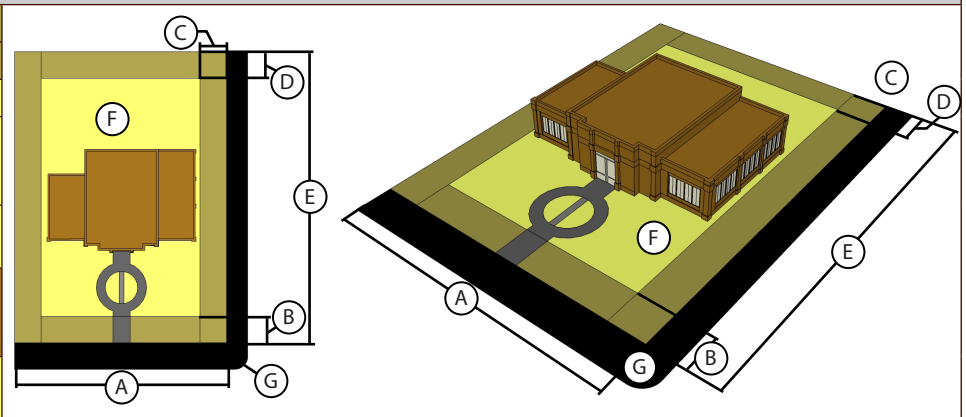

(A) Frontage	(D) Rear Setback	(G) Public Sidewalk
(B) Front Setback	(E) Depth	
(C) Side Setback	(F) Buildable Lot Area	

- e. **Permitted Uses.** The uses permitted in the NB district are specified in Table 5-1 as either "permitted" or "administrative" or "conditional."
- f. **Site and Building Design Standards.** Due to the more compact development pattern, and the important relationship and integration between uses sites and buildings in this district with adjacent neighborhoods, all uses in the NB district shall meet the Small-scale Mixed-use and Commercial Design Standards in Section 6.7. These standards shall apply to the design of buildings, sites, open spaces and streetscapes in order to create a walkable, mixed-use environment among this district and the various adjacent and supporting zoning districts.

ARTICLE 5 ZONING REGULATIONS

5.4 COMMERCIAL AND MIXED-USE DISTRICTS STANDARDS

5.4.2 CB – Community Business District

- a. **Intent.** The CB District is intended for Retail, Employment, Service and Civic uses that may serve a number of residential neighborhoods or other districts in meeting daily needs, discretionary needs, or other business functions. The district regulations are designed to encourage these uses, while also protecting the abutting and nearby areas.
- b. **Applicability.** The CB District is applicable in areas where moderate- or large-scale business uses are appropriate, specifically larger Mixed-use Commercial Activity Centers, Community/Regional Activity Centers, or Community Business areas of the Comprehensive Plan.
- c. **Context.** The total area of the district may be between 20 and 100 acres, with over 125,000 square feet of Retail uses for the entirety of the district (individual applications may be smaller). Larger and more intense applications within this range should be limited to Regional Centers located between 2 to 5 miles from other similar districts and smaller mixed-use and activity centers. This district should employ a well connected internal network to facilitate a park-once, walkable atmosphere and good internal circulation, and transitions to adjacent areas should be designed to minimize impacts on surrounding areas and transportation networks.
- d. **Lot and Building Standards.**

TYPE CB: COMMUNITY BUSINESS LOT AND BUILDING STANDARDS		
Lot Area		n/a
Lot Frontage		n/a
Setbacks: (Min)	Front	All buildings shall be set back 25' from all property lines adjacent to streets.
	Side	
	Rear	
Building Height		n/a
Maximum Coverage		85%

- e. **Permitted Uses.** The uses permitted in the CB district are specified in Table 5-1 as either “permitted” or “administrative” or “conditional.”
- f. **Site and Building Design Standards.**
 1. The Large-scale Commercial Design Standards in Section 6.8 may apply to buildings in this District, according to the provisions of that section.
 2. The City Council may elect to apply the Small-scale

Mixed-use and Commercial Design Standards in Section 6.7 as a condition to the rezoning to the CB District where it is located in an Activity Center designated in the Comprehensive Plan or a pedestrian-oriented environment is desired. In those instances, any conflict between Section 6.7 and this section shall be resolved in favor of the design guidelines in Section 6.7.

- 3. All other CB lots shall be subject to the General Commercial Design Standards in Section 6.9.

5.4.3 CBD – Central Business District

- a. **Intent.** The CBD is intended for a wide range of Retail, Employment, Service, Civic, Residential, and Public uses forming the financial, governmental, and cultural core of the community. A balance of old and new development as well as the preservation and restoration of noteworthy buildings is desired. The district regulations are designed to promote diverse activity, more intensive development, and continuation of the traditional urban form of downtown.
- b. **Applicability.** The CBD district is applicable to the central urban core of the City, specifically the CBD designation in the Comprehensive Plan.
- c. **Context.** It requires a tightly integrated network of diverse streets, which should be maintained and reinforced through any redevelopment.
- d. **Lot and Building Standards.**

TYPE CBD: CENTRAL BUSINESS DISTRICT LOT AND BUILDING STANDARDS		
Lot Area		n/a
Lot Frontage		n/a
Setbacks:	Front	0'
	Side	0'
	Rear	0'
Building Height		n/a
Maximum Coverage		100%

- e. **Permitted Uses.** The uses permitted in the CBD district are specified in Table 5-1 as either “permitted” or “administrative” or “conditional.”

5.4.4 MUR - Mixed-use Residential District

- a. **Intent.** The MUR District is intended for a mix of Residential, Retail, Service, Employment, and Civic uses where the predominant use will be Residential, with moderate or higher densities and a range of housing types. Non-residential uses should be limited to those that primarily support residential uses within the district. The district regulations are designed to allow a variety of housing types, and establish the necessary amenities to support higher-density urban neighborhoods.
- b. **Applicability.** The MUR District is applicable to areas where more urban, higher-density and walkable residential neighborhoods are desired and are appropriate with a high level of pedestrian and civic amenities, specifically areas designated Mixed-use Residential Emphasis in the Comprehensive Plan.
- c. **Context.** This district is also appropriate to establish transitions around Mixed-use Commercial Activity Centers and Community/Regional Commercial Activity Centers, or for achieving density along higher-traffic corridors and transit routes. Retail business should primarily support residential uses in or immediately adjacent to the neighborhood. The MUR district requires a highly connected transportation network within the district and surrounding areas, with smaller blocks and pedestrian-oriented streetscapes on the primary streets.
- d. **Lot and Building Standards.** The lot and buildings standards in the MUR district shall be a combination of those allowed in the NR-2 district and those allowed in the NB district.
- e. **Permitted Uses.** The uses permitted in the MUR district are specified in Table 5-1 as either “permitted” or “administrative” or “conditional.”
- f. **Site and Building Design Standards.** Due to the more compact development pattern, and the important relationship and integration between uses, sites and buildings in the MUR district, the following site and building standards shall apply:
 1. Urban loft, commercial or mixed-use lots and building types shall apply the Small-scale Mixed-use and Commercial Design Standards in Section 6.7.
 2. Residential lots and building types shall apply the Residential Design Standards in Section 6.6.

5.4.5 MUB – Mixed-use Business District

- a. **Intent.** The MUB District is intended for a diverse mix of Residential, Retail, Service, Employment and Civic uses integrated into a walkable compact development pattern. Non-residential uses may serve adjacent or nearby neighborhoods, as well as uses within the district, where transitions in the intensity of use and scale of buildings ensure compatibility with those neighborhoods. This district is also intended as an alternative format for moderate or larger scale commercial uses than that of the CB District. The district regulations are designed to allow a wide variety of compatible uses, and establish the necessary relationship between these uses, civic amenities, and the public realm.
- b. **Applicability.** The MUB District is applicable to areas where more intense development and diverse mix of uses is appropriate with a high level of pedestrian and civic amenities, specifically areas designated Mixed-use Commercial Emphasis, Mixed-use Commercial Activity Centers, and Community/Regional Commercial Activity Centers in the Comprehensive Plan.
- c. **Context.** The district should be located at least 1 to 1 ½ miles from similar districts or other activity centers. The district should primarily feature businesses that serve a typical target market area of ½ to 1½ miles for the majority of its on-site business. The MUB district requires a highly connected transportation network within the district and surrounding areas, with smaller blocks and pedestrian-oriented streetscapes on the primary streets.
- d. **Lot Standards.** The lot and buildings standards in the MUB district shall be a combination of those allowed in the NR-3 district and in the NB district, and the following lot standards specifically to accommodate larger commercial and mixed-use building sites in a compact, walkable setting:

ARTICLE 5 ZONING REGULATIONS

5.4 COMMERCIAL AND MIXED-USE DISTRICTS STANDARDS

TYPE MUB: LARGE MIXED-USE/ COMMERCIAL LOT AND BUILDING STANDARDS		
Lot Area	20,000 square feet minimum	
Lot Frontage	25' minimum	
Setbacks:	Front	0' to 20'
	Side	0' if partywall; 5' otherwise
	Rear	5' if alley; 15' otherwise
Building Height	3 stories Maximum 4 or more stories with conditional review	
Total Lot Coverage	90% maximum	

- e. **Permitted Uses.** The uses permitted in the MUB district are specified in Table 5-1 as either “permitted” or “administrative” or “conditional.”
- f. **Site and Building Design Standards.** Due to the more compact development pattern, and the important relationship and integration between uses, sites and buildings in the MUB district, the following site and building standards shall apply:
1. Urban loft, commercial or mixed-use lots and building types shall apply Small-scale Mixed-use and Commercial Design Standards in Section 6.7.
 2. Residential lots and building types shall apply the Residential Design Standards in Section 6.6.

5.4.6 MUE- Mixed-use Employment District

- a. **Intent.** The MUE District is intended a diverse mix of Employment, Light Industrial, and Civic uses integrated into a campus-like environment. Limited Retail, Service, and Residential uses may also support the overall plan for the area but not be a dominant factor in the land uses and design. All development shall be organized around public or common open spaces, including a well connected transportation network, that creates a unifying framework and character for the entire district, and which creates effective urban design and land use intensity transitions to surrounding development patterns.
- b. **Applicability.** The MUE District is applicable to areas where significant employment-based economic development opportunities exist and where improved pedestrian and civic amenities can coordinate development of compatible uses and designs, specifically areas designated Mixed-use Employment Campus or Industrial in the Comprehensive Plan.
- c. **Context.** The district can effectively be located as extensions of Activity Centers where designed with

appropriate connections to these areas. This can allow for slightly less stringent urban design standards for the MUE area, while providing a large daytime population within walking distance to help support the commercial activity in the adjacent centers. The MUE district requires a connected transportation network within the district and surrounding areas, with smaller blocks and pedestrian-oriented streetscapes on the primary streets, although centralized greenspace can serve as connections for non-motorized travel in a campus-type environment.

- d. **Lot Standards.** The lot and building standards in the MUE district shall be a combination of those allowed in the NB district, plus the following lot standards specifically to accommodate Employment and Light Industrial uses:

TYPE MUE: MIXED-USE EMPLOYMENT DISTRICT LOT AND BUILDING STANDARDS		
Lot Area	10,000 square feet Minimum	
Lot Frontage	80' – 250' except no maximum for any lots fronting on a public or common open space or on a Parkway street type.	
Setbacks:	Front	25' Minimum 10' to 20' for lots fronting on a Boulevard, Avenue, or Pedestrian Street street type or fronting on any public or common open space.
	Side	10'
	Rear	20'
Building Height	3 stories Maximum Up to 6 stories with conditional review and if fronting on public or common open space or on a Parkway street type.	
Total Lot Coverage	Minimum FAR .25 Maximum Lot Coverage 80% (excluding required open space)	

- e. **Permitted Uses.** The uses permitted in the MUE district are specified in Table 5-1 as either “permitted” or “administrative” or “conditional.”
- f. **Site and Building Design Standards.** Due to the unique development pattern and the important relationship and integration between uses, sites and buildings in the MUE district, the following site and building standards shall apply:
1. **Master Development Plan.** Any MUE district may be proposed according to an overall master plan that alters the Lot Standards, Site and Building Design Standards, and Transition Standards of this section,

provided the master development plan equally or better meets the intent of this district.

2. *Required Open Space / Common Area.* Each lot shall contribute to the overall public or common open space for the district according to the following:
 - (a) A minimum of 15% allocated Green, Plaza, Square or Courtyard, Pocket Park/Gateway types in Section 4.4
 - (b) A minimum of 20% is required if the Floor Area Ratio is above .75.
 - (c) A minimum of 20% is required if any portion of the open space is a Natural Area or Trail Corridor types in Section 4.4.
 - (d) Pocket Parks / Gateways shall be required at each location where an Arterial Street is intersected by a Collector Street or higher. These areas may count towards the required open space.
 - (e) A minimum 20' landscape buffer shall be required in addition to any required setbacks and open space when building heights are more than 1.5 times the height allowed in any adjacent or abutting residential use or zoning district.
3. *Building Elements.* All buildings shall include the following elements:
 - (a) *Primary Entrance Features.* All buildings shall have a primary entrance feature oriented towards the lot frontage. The entrance feature shall have direct pedestrian connections to the public streetscape or public or common open space with minimal interruptions by parking areas or driveways.
 - (b) *Horizontal Massing.* Any building with a front façade width greater than 150' shall have differentiated horizontal massing through any combination of the following:
 - (1) Differentiated structural bays every 25' to 50', demonstrated by a vertical expression line of trim or ornamental architectural elements that distinguish it from the rest of the facade;
 - (2) An intervening courtyard or plaza meeting the requirements of sub-section 6.6.6., resulting in no single portion of horizontal façade greater than 75';
 - (3) Off-sets in the façade of between 3' and 10', associated with enhanced landscape features or other similar civic amenities.
 - (c) *Façade Openings.* Each facade shall have openings at street level or on public or common open space according to the following:
 - (1) Retail and Service uses shall have between 60%

and 90% of all street-level facades between 2' and 10' above grade shall be transparent with views to the interior of the building. No window starting at a level of greater than 3.5' above the street level should be included in the calculation. Where the interior operation or program of the building warrants screening from the street, a closed display window of at least 2.5' in all dimensions may be substituted along up to 50% of the linear distance of the façade.

- (2) Employment and Light Industrial Uses located within 30' of any public right-of-way or any public or common open space, between 40% and 70% of all street-level facades between 2 and 10' above grade shall be transparent with views to the interior of the building. No window starting at a level of greater than 3.5' above the street level should be included in the calculation. Where the interior operation or program of the building warrants screening from the street, these portions of the building shall be located away from the street frontage or public and common open space.
4. *Site Screening.* Any delivery and service areas, external support equipment, site utility areas, or other similar high-impact elements of site and building design shall be subject to the following:
 - (a) All delivery or service areas and loading docks shall be located on a discrete façade, and internal to the block wherever possible.
 - (b) Any rooftop equipment shall be screened from view from the adjacent public streetscape or other public or common opens spaces by a parapet on flat roofs, or located on a discrete pitch for pitched roofs.
 - (c) Any service areas, loading docks, service equipment, or other site utility area that is visible from adjacent property or public right-of-way shall be screened with a landscape buffer.
 - (d) Any use that involves vehicle service bays on a primary or secondary façade shall be located on only secondary or support streets, shall have the service bay portion of the building set back at least 30' from the lot frontage, and shall not have service bays that front on Parkways, Boulevard, Avenue, or Pedestrian Street types.

5.4.7 BP – Business Park

- a. **Intent.** The Business Park (BP) district is intended to support small and large-scale industrial development while providing essential commercial services along regional transportation routes in an industrial park setting. The district integrates manufacturing, processing, research and development, and shipping activities in addition to retail, dining, and convenience stores to enhance functionality and appeal for businesses and employees.
- b. **Applicability.** The BP district is applicable to areas on the edge of the community that are intended to support large-scale industrial, manufacturing, shipping, research and development, and data center uses. The district is typically found close to major transportation routes, making commercial uses appropriate. The district shall contain not less than 320 acres of land (interrupted only by roads, railroads, highways and natural features (such as ridges and waterways). Specifically, large-scale areas within the future land use designations in the comprehensive plan of Community Business, Mixed-Use Employment, and Industrial – including Community/Regional Activity Centers. Areas currently designated Agricultural/Rural (either inside or outside of the Urban Service Boundary) may also be appropriate for this zone district if near to regional transportation routes and if development of the area extends appropriate infrastructure.
- c. **Context.** This district is most appropriate in areas with large acreage and access to major regional transportation infrastructure.
- d. **Lot and Building Standards.**

- e. **Permitted Uses.** The uses permitted in the BP district are specified in Table 5-1 as either “permitted” or “administrative” or “conditional.”
- f. **Site and Building Design Standards.** Due to the nature of development and context of this zone district, the following development standards shall apply to development in the BP zone.
 1. **Parking, Lot Access, and Circulation.** The minimum required Automobile Parking standards of UDC 6.2.4.a shall not apply to property within the BP district.
 2. **Landscaping.** Development shall comply with the standards of UDC 6.3, Landscaping Standards, with the following modifications:
 - (a) **Tree Requirement.** Instead of requiring tree points (UDC 6.3.4.a), every development shall plant one (1) tree for every one hundred (100) feet of street frontage. Trees shall be planted within 100’ of a right-of-way, within 15’ of a parking lot, or within 20’ of a building.
 - (b) **Shrub Substitution.** In lieu of planting trees, a developer may opt to plant six (6) shrubs as a substitute for each required tree.
 - (c) **Street Trees.** The Street Tree requirements of UDC 6.3.6 shall not apply.
 - (d) **Common Landscape Plan.** The submittal of a Common Landscape Plan and the standards within UDC 6.3.10 shall not apply.
 3. **Building Design Standards.** Any development not in the “Industrial Uses” category in Section 5.1.4, Table 5-1 shall comply with the design standards of UDC 6.9 (or UDC 6.8 if meeting the applicability of UDC 6.8).

TYPE BP: BUSINESS PARK DISTRICT LOT AND BUILDING STANDARDS		
Lot Area		n/a
Lot Frontage		n/a
Setbacks:	Front	All buildings shall be set back 25’ from all property lines adjacent to streets; 10 feet from all other internal property lines; and 25 feet from all property lines shared with another zone district.
	Side	
	Rear	
Building Height		n/a
Maximum Coverage		90%

5.5 Industrial Districts Standards

- 5.5.1 LI – Light Industrial District
- 5.5.2 HI – Heavy Industrial District

5.5.1 LI – Light Industrial District Standards

- a. **Intent.** The LI district is intended for environmentally controlled manufacturing or intensive employment uses that may have accessory commercial, service or office uses, but which cannot readily fit into other general business or mixed-use areas due to the nature or intensity of operations. The uses and building and site designs associated with uses in this district produce little or no impacts beyond the property lines.
- b. **Applicability.** The LI district is applicable to larger land areas that are capable of providing substantial buffers to adjacent sites, buildings, and land uses to minimize the potential for incompatible and negative impacts of uses in the district.
- c. **Context.** This district is most appropriate in areas with access to major regional transportation infrastructure, specifically areas designated Industrial in the Comprehensive Plan, and in limited applications within Mixed-use Employment Campus in the Comprehensive Plan. The district should be sized according to market demands and employment forecasts.
- d. **Lot and Building Standards.**

TYPE LI: LIGHT INDUSTRIAL LOT AND BUILDING STANDARDS		
Lot Area	n/a	
Lot Frontage	n/a	
Setbacks:	Front	All buildings shall be set back 25' from all property lines adjacent to streets.
	Side	
	Rear	
Building Height	n/a	
Maximum Coverage	85%	

- e. **Permitted Uses.** The uses permitted in the LI district are specified in Table 5-1 as either “permitted” or “administrative” or “conditional.”

5.5.2 HI – Heavy Industrial District Standards

- a. **Intent.** The HI district is intended for uses of very high intensity which should be isolated and buffered in order to protect the community and to ensure unimpeded operation of the use. These uses do not fit into other general business or mixed-use areas due to the nature or intensity of operations. The uses and building and site designs associated with uses in this district can produce impacts beyond the property lines, and the district should be remote from other differing and incompatible land uses.
- b. **Applicability.** The HI district is applicable to larger land areas that are remote from other differing or incompatible to minimize the potential for incompatible and negative impacts of uses in the district.
- c. **Context.** This district is most appropriate in areas with access to major regional transportation infrastructure, specifically areas designated Industrial in the Comprehensive Plan. The district should be sized according to market demands and employment forecasts and the inherent suitability of particular land areas to meet the intent of the district.
- d. **Lot and Building Standards.**

TYPE HI: HEAVY INDUSTRIAL LOT AND BUILDING STANDARDS		
Lot Area	n/a	
Lot Frontage	n/a	
Setbacks:	Front	40'
	Side	40'
	Rear	40'
Building Height	n/a	
Maximum Coverage	90%	

- e. **Permitted Uses.** The uses permitted in the HI district are specified in Table 5-1 as either “permitted” or “administrative” or “conditional.”

5.6 Special Purpose and Overlay Districts Standards

- 5.6.1 P – Public District
- 5.6.2 PUD – Planned Unit Development District
- 5.6.3 AD – Airport District
- 5.6.4 M – Military District
- 5.6.5 AHR – Airport Height Restriction Overlay
- 5.6.6 CHR – Capital Height Restriction Overlay
- 5.6.7 RUCAO – Restricted Use Control Area Overlay District
- 5.6.8 Support Services
- 5.6.9 UU – Urban Use Overlay District

5.6.1 P – Public District Standards

- a. **Intent.** The P district is intended primarily for public sites, buildings and uses where activities conducted provide service to the public, including educational facilities, recreational areas, and community service facilities. The sites, buildings, and uses in this district may create important identifying features of the neighborhoods and centers of the City, and should incorporate distinctive civic architecture and site design that emphasizes Cheyenne’s regional architectural identity through character, quality, and authenticity where appropriate.
- b. **Applicability.** The P district is applicable to government buildings and uses in areas where it is necessary to support adjacent or nearby development with public services or facilities, and specifically the Parks and Open Space or Public and Quasi-public future land use categories in the Comprehensive Plan.
- c. **Context.** If property or a portion of property with this classification is sold or transferred to a nongovernmental entity, the classification shall be changed before the property can be utilized. The uses permitted in the P District may also be allowed as secondary or support uses in other zoning districts according to the standards of the other zoning districts, so it is not always necessary to rezone to the P District. However, the P District is applicable where the standards of those other districts conflict with the governmental function, and special consideration for government uses are necessary.
- d. **Lot and Building Standards.** Due to the variety of contexts in which the P District may apply, and the differing types of support activities that are appropriate in this district, the following lot types, building types and dimensions specified in the tables are permitted in the P district. Any building or site configuration in the P district that does not meet the following lot and building standards shall require a campus plan or master plan subject to the alternative standards process in sub-section h below:
 - 1. *Small Civic Building* (Type P-CV1). This type is intended for small-scale civic uses that fit within the surrounding development pattern and block structure and which provide support the immediately adjacent neighborhood and zoning districts. Examples include a neighborhood school, police or fire sub-station, neighborhood center or similar buildings.
 - 2. *Medium Civic Building* (Type P-CV2). This type is intended for medium scale civic uses that serve as prominent features and destinations of the surrounding neighborhood or zoning district. While they fit within the existing development pattern and block structure, they may occupy large portions of blocks and serve as landmarks for the area. Examples include larger schools, libraries, or community centers.
 - 3. *Prominent Civic Building* (Type P-CV3). This type is intended for large-scale civic uses that are regional destinations and due to their size and accessibility often require sites that may disrupt the surrounding block structure or development pattern. Designs that promote a “campus” layout assist with relating the building and sites to surrounding development and meeting the intent and applicability of this district. Examples include a large regional school, prominent public or government building, or major community event facility.
 - 4. *Open Space* (Type P-OS). This type is intended for parks and open space. Parks and open space shall be developed according to the Parks and Recreation Department standards, except that where these areas include buildings, facilities, or parking areas at least 25’ surrounding any building or parking area shall meet the Landscape Standards in Section 6.3.
- e. **Permitted Uses.** The uses permitted in the P district are specified in Table 5-1 as either “permitted” or “administrative” or “conditional.”
- f. **Accessory Uses.** Due to the public nature and Intent of the P District, accessory uses in the P district may be expanded

beyond those that are customarily incidental to other permitted uses. Any government owned and operated facility in the P District may also include additional accessory uses that are consistent with the public mission of the facility, are incidental to the primary purpose of the lot and building, and do not require any special design features that are inconsistent with the standards in this section. Examples include coffee shops or food concessions associated with public buildings.

g. **Performance Standards.** Due to the important civic function and support nature of the P District to other zoning districts, all uses in the P district shall meet the following performance standards:

1. Parking in the P District shall be provided according to the following:
 - (a) There is no minimum parking requirement. The City may require parking based on the most closely associated use requirements in Section 6.2, and parking maximums shall be according to the most closely associated use and requirements in Section 6.2.
 - (b) Any parking that is provided shall be designed according to the design standards in Section 6.2.
 - (c) Any parking that is provided should be designed for dual use, so that it accommodates parking needs in limited peak parking times but has appearances and function for other purposes during non-parking periods. Examples include: playgrounds designed for occasional parking; plazas or courts designed for occasional parking; stabilized turf surfaces; areas designed for special events such as concerts, festivals or markets which accommodate parking; or other similar dual purpose areas that emphasize the civic nature of sites in the P district.
 - (d) All sites in the P District should be located on or utilize street types that maximize on-street parking wherever possible. These street types will (1) calm traffic near parks or other civic activity areas and (2) minimize amount of site dedicated to surface parking.
2. Any fencing within 25' of the public right-of-way shall require:
 - (a) ornamental fencing, such as wrought iron, coated or colored chain link, or other designs intended to minimize the visibility of the fence; or

(b) include a Level 1 Buffer according to Section 6.3.5 of the Landscape Standards between the fence and the right-of-way.

3. All sites for the Small, Medium and Large Civic Buildings (Types P-CV1, P-CV2, and P-CV3) shall incorporate Civic Open Space meeting the standards of section 4.4 of the Unified Development Code.
4. All sites shall meet the Landscape Standards in Section 6.3, except that Open Spaces (Types P-OS) shall meet the following:
 - (a) At least 25' surrounding any building or parking area shall meet the Landscape Standards in Section 6.3.
 - (b) All additional grounds shall be designed according to Section 4.4.1, 4.4.3, and 4.4.4 of the Unified Development Code and meet the Parks and Recreation Specifications for landscape and facility design.
5. All buildings should incorporate the Regional Architectural Identity concepts in Section 2 of the Structure Plan of *PlanCheyenne* and submit details (research, precedents, etc.) demonstrating how these concepts are reflected in the proposed designs.

h. **Alternative Standards Process.** The P District is intended to allow public and quasi-civic uses and site development that supports private development otherwise allowed in the UDC, all in conformance with the City's Comprehensive Plan. The P district is not intended to specifically regulate public uses such as fire stations, libraries, or community centers in any other manner than to generally ensure that they support the broader interests of the immediately adjacent areas and the community as a whole. The P district establishes basic standards that can facilitate this intent, but these standards are absent any specific site or context. Alternatively, when these facilities undergo a process with stakeholders to develop the preferred functions, usage, and site and building design, alternative standards may be approved in the City's discretion. Through that process, standards that are specific to a site or context may be developed. At a minimum, any alternative standards shall be consistent with the following:

1. Good civic design, including the Gateways and Landmarks concepts in *PlanCheyenne* (See Structure, Section 3), and the Regional Architectural Identity Concepts in *PlanCheyenne*. (See Structure, Section 2.)
2. The Intent and Applicability of the P District, and the Intent of any abutting zoning districts for which this particular application of the P District is intended to support.

ARTICLE 5 ZONING REGULATIONS

5.6 SPECIAL PURPOSE AND OVERLAY DISTRICTS STANDARDS

TYPE P-CV1: SMALL CIVIC BUILDING		
Lot Area	2,000 – 12,500 square feet	
Lot Frontage	25' – 100'	
Setbacks:	Front	10' to 35' [a]
	Side	7% of lot frontage on each side, up to 10' maximum required setback
	Rear	15' 5' if alley loaded
Building Height	1 to 2 stories Up to 3.5 stories as conditional review	
Total Lot Coverage (max.)	80%	

[a] Less than 25' only permitted for front or street-side setbacks with frontage along Boulevard, Avenue, or Pedestrian Street types according to Section 4.3 of these regulations.

TYPE P-CV2: MEDIUM CIVIC BUILDING		
Lot Area	12,000 s.f. - 80,000 s.f.	
Lot Frontage	300' maximum	
Setbacks:	Front	25'; or 10' [a]
	Side	10% of lot frontage, up to 20' maximum requirement
	Rear	25' 10' alley loaded
Building Height	1 to 2 story Up to 3.5 stories as conditional review	
Total Lot Coverage (max.)	80%	

[a] Reduced minimum setback only permitted for front or street-side setbacks with frontage along Boulevard, Avenue, or Pedestrian Street types according to Section 4.3 of these regulations.

(A) Frontage	(D) Rear Setback	(G) Public Sidewalk
(B) Front Setback	(E) Depth	
(C) Side Setback	(F) Buildable Lot Area	

ARTICLE 5 ZONING REGULATIONS

5.6 SPECIAL PURPOSE AND OVERLAY DISTRICTS STANDARDS

TYPE P-CV3: PROMINENT CIVIC BUILDING

Lot Area		80,000 s.f. minimum
Lot Frontage		200' minimum 600' maximum [b]
Setbacks:	Front	50'; or 20' [a]
	Side	50'; or 20' [a]
	Rear	50' 20' if abutting alley
Building Height		3 story
Total Lot Coverage (max.)		80%

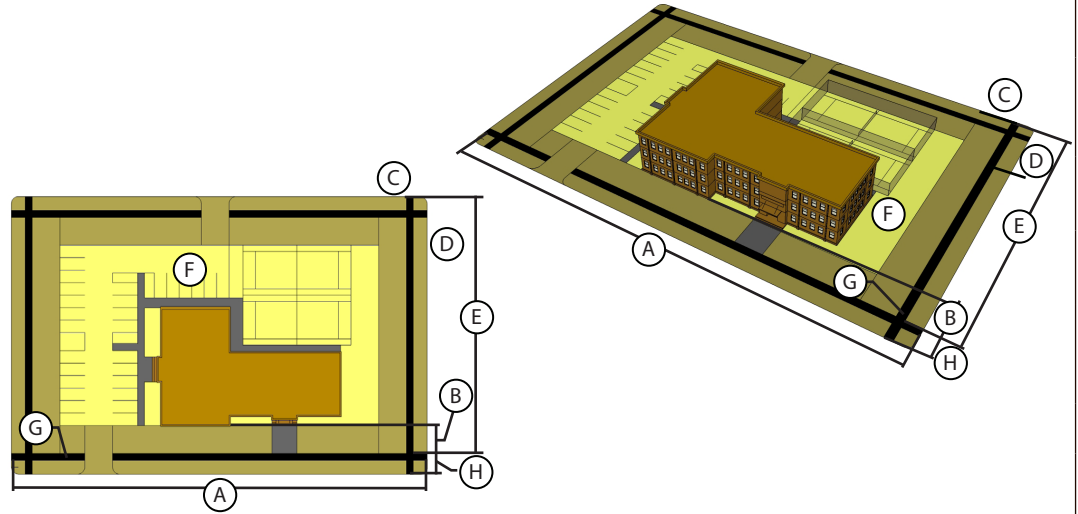

- [a] Reduced minimum setback only permitted for front or street-side setbacks with frontage along Boulevard, Avenue, or Pedestrian Street types according to Section 4.3 of these regulations.
- [b] Lot frontages larger than 600' are only permitted for Civic buildings that include a campus layout with mid-block pedestrian connections allowing permeability of the oversized block

(A) Frontage	(D) Rear Setback	(G) Public Sidewalk
(B) Front Setback	(E) Depth	(H) Public Right-of-way
(C) Side Setback	(F) Buildable Lot Area	

TYPE P-OS: OPEN SPACE

Lot Area		Subject to Section 4.4 and Parks and Recreation Specifications
Lot Frontage		Subject to Section 4.4 and Parks and Recreation Specifications
Setbacks: (min.)	Front	25'
	Side	25'
	Rear	25'
Building Height (max.)		2 stories
Total Lot Coverage (max.)		10%

- Meet the Intent or Design Objectives of all other applicable site and building standards, or propose a unique and exemplary plan and design that equally or better meets the Intent and Design Objectives of those standards.

5.6.2 PUD – Planned Unit Development District

- Intent.** A planned unit development shall permit flexibility and creativity in site and building design and location in accordance with an approved plan and specific ordinance, which shall be written in a manner as to prevent adverse impacts and protect the public health, safety and welfare. Design excellence and the provision of outstanding public amenity shall be considered when establishing development standards.
- Applicability.** The planned unit development ordinance shall be considered the zoning ordinance for the property described in that ordinance.
- Context.** A planned unit development designation is appropriate when at least one of the following is incorporated:
 - Development of compatible land uses providing private and common spaces for recreation, circulation and open space;
 - Conservation of natural features or development of desirable amenities. The use of woonerfs is encouraged

- for residential developments;
3. Creation of areas for mixed uses not ordinarily permitted together in other districts that are of benefit to the development and that are so designed as to prevent negative impacts to the surrounding areas. Industrial uses may be developed with other uses when the negative impacts are proven to be mitigated;
 4. Creation of large areas for a wide variety of retail uses, such as shopping centers and their associated developments, so that these uses can benefit from the combined planning standards.
- d. **Minimum District Area.** The minimum district area for planned unit developments is:
1. 2.0 acres for undeveloped land.
 2. 0.5 acres of redeveloping land
- Smaller areas may be considered when the proposed PUD clearly provides exceptional public benefits.
- e. **Sketch Plan.** Any applicant may submit a sketch plan detailing the applicant's intent. The plan may be forwarded to the commission for review only. Comments shall not be construed as an approval of any sketch plan. Sketch plans and documents should address the appropriate items listed in sub-section f. The sketch plan may also be used for the conceptual planning meeting required by Section 2.2.2.
- f. **Preliminary Plan.** An applicant shall submit an application for a preliminary development plan containing concepts, standards and phasing for the full build out of the subject property according to procedures and criteria in Article 2 and draft ordinance for approval. Any ordinance rezoning property to the PUD district shall include the following according to the preliminary development plan, or as otherwise specified in the ordinance:
1. Uses by right and location;
 2. Uses permitted by Board approval and location;
 3. Lot and building standards, specifying where they are different from the most similar base zoning district requirements. Lot and building standards shall include the following for each different lot and building type in the plan:
 - (a) Lot frontage;
 - (b) Lot size;
 - (c) Lot coverage;
 - (d) Building height; and
 - (e) Setback, build-to lines, or other building orientation specifications;
4. Building design standards, specifying where they are different from what would be required by Section 6.6 for residential buildings and lots, 6.7 for small-scale commercial buildings and lots, or 6.8 for large-scale commercial buildings or lots;
 5. Landscape, buffering and screening requirements, specifying where they are different from what would be required by Section 6.3;
 6. Common open space or facilities and design types, where they are different from what would be required by Section 4.4;
 7. Signage requirements and regulations, specifying where they are different from what would be required by Section 6.5;
 8. Parking requirements, specifying where they are different from what would be required by Section 6.2;
 9. Development performance standards;
 10. Proposed ownership of common facilities;
 11. A statement on how proposed deviations from otherwise required standards support the proposed plan, and result in design excellence and outstanding public amenity that is otherwise not allowable under general zoning standards; and
 12. Any other requirements and restrictions that meet the intent of this district.
- g. **Final Plan.** Any development in the PUD district shall require a submittal of a Final Plan according to the procedures and criteria in Section 2.2.2.
- h. **Amendments.** Amendments proposed in the Final Plan shall only be permitted as specified within the bounds of the preliminary development plan or ordinance approving the PUD, or as permitted by Administrative Adjustment according to the procedures and criteria in Section 2.3.4. All other amendments shall be processed as an amendment to the zoning and preliminary development plan.
- i. **Existing Planned Unit Developments.** All planned unit developments which have been approved and are shown on the zoning maps at the effective date of the ordinance codified in this Title shall be developed in the manner in which they were originally approved. All existing planned unit development ordinances and resolutions shall be a supplement to this code and shall be on file with the Development Office and the City Clerk. Any planned unit developments shown on the zoning maps that do not have a specific planned unit development ordinance or resolution shall have an ordinance approved by the City

ARTICLE 5 ZONING REGULATIONS

5.6 SPECIAL PURPOSE AND OVERLAY DISTRICTS STANDARDS

Council, prior to any future development or changes of use within that planned unit development district.

5.6.3 AD – Airport District Standards

- a. **Intent.** The AD district is intended to provide for logical development of the airport property for an airport and related facilities and uses.
- b. **Applicability.** The AD district is applicable to areas owned by the Airport Board and the state of Wyoming at the Cheyenne Regional Airport.
- c. **Context.** In addition to the general district requirements, prior to the initial development of any land in this district located north of the residential area bounded on the west by Morrie Avenue and on the east by Converse Avenue a hearing shall be required on the development plan by the Airport Board with approval of the development plan by the City Council. After Council approval, the site plan procedures will be used.
- d. **Lot and Building Standards.**

TYPE AD: AIRPORT DISTRICT LOT AND BUILDING STANDARDS		
Lot Area	n/a	
Lot Frontage	n/a	
Setbacks:	Front	25'
	Side	25'
	Rear	25'
Building Height	n/a	
Maximum Coverage	85%	

- e. **Permitted Uses.** The uses permitted in the AD district are specified in Table 5-1 as either “permitted,” “administrative” or “conditional.”
- f. **Site and Building Design Standards.** All uses in the AD district are subject to site plan review. To further protect the public health, safety and welfare as well as preserve this distinct for airport and other airport development uses, these additional restrictions apply:
 - 1. **Liquid and Solid Wastes.** Storage of animal, vegetable or other wastes which attract insects, rodents, or birds or otherwise create a health hazard shall be prohibited.
 - 2. **Discharge Standards.** There shall be no emission of

smoke, fly ash, dust, vapor, gases or other forms of air pollution that may cause nuisance or injury to human, plant or animal life, or to property, or that may conflict with any present or planned operations of the airport.

- 3. **Lighting.**
 - (a) Sign lighting shall not project directly into an adjoining residential district.
 - (b) Unless necessary for safe and convenient air travel, sign lighting and exterior lighting shall not project directly into the runway, taxiway or approach zone.
- 4. **Glare and Electromagnetic Interference.**
 - (a) Building materials shall not produce glare which may conflict with present or planned operations of the airport.
 - (b) No use may produce electromagnetic interference which may conflict with any present or planned operations of the airport.

5.6.4 M – Military District Standards

- a. **Intent and Context.** The M district consists of property owned and controlled by the United States Government and further known as F.E. Warren AFB. These lands are not subject to local regulation, as they are under the jurisdiction of the federal government. If the property or portions of the property with this classification are sold or transferred to any entity other than the United States Government, the district classification shall be changed before the property can be utilized.

5.6.5 AHR - Airport Height and Use Restrictive Overlay District

- a. **Intent.** The AHR district has been created because an obstruction to airspace has the potential for endangering the lives and property of users of the Cheyenne Airport, and property or occupants of land in its vicinity. That obstruction may affect existing and future instrument approach minimums of the Cheyenne Airport. The obstruction may reduce the size of areas available for the landing, takeoff and maneuvering of aircraft, thus tending to destroy or impair the utility of the Cheyenne Airport and the public investment in that facility.
- b. **Definitions.** The following definitions are specific to this district and are used to clarify the provisions of this district.

“Airport” means an area of land set aside for the landing and taking off of aircraft, and utilized or to be utilized in the interest of the public for such purposes and commonly known as the Cheyenne Airport.

“Airport elevation” means the highest point of an airport’s usable landing area measured in feet above mean sea level. This is six thousand one hundred fifty-six (6,156) feet above sea level for the Cheyenne Airport.

“Airport operator” means the Cheyenne Airport Board whose responsibility it is to maintain and operate the airport.

“Approach surface” means a surface longitudinally centered on the extended runway centerline, extending outward and upward from the end of the primary surface and at the same slope as the approach zone height limitation slope set forth in Sub-section d. The perimeter of the approach surface coincides with the perimeter of the approach zone.

“Approach, Transitional, Horizontal and Conical Zones.” These zones apply to the area under the approach, transitional, horizontal and conical surfaces defined in Part 77 of the Federal Aviation Regulations as set forth in Sub-section c.

“Conical surface” means a surface extending outward and upward from the periphery of the horizontal surface at a slope of twenty to one (20:1) for a horizontal distance of four thousand (4,000) feet.

“Hazard to air navigation” means an obstruction determined to have a substantial adverse effect on the safe and efficient utilization of the navigable airspace.

“Height” means for the purpose of determining the height limits in all districts set forth in this Section, the datum shall be mean sea level elevation unless otherwise specified.

“Horizontal surface” means a horizontal plane one hundred fifty (150) feet above the established airport elevation, the perimeter of which coincides with the perimeter of the horizontal zone. This is six thousand three hundred six (6,306) feet above the mean sea level for the Cheyenne Airport.

“Larger than utility runway” means a runway that is constructed for and intended to be used by propeller-driven aircraft of greater than twelve thousand five hundred (12,500) pounds maximum gross weight and jet-powered aircraft.

“Nonprecision instrument runway” means a runway having

an existing instrument approach procedure utilizing air navigation facilities with only horizontal guidance, or area-type navigation equipment, for which a straight-in nonprecision approach procedure has been approved or planned.

“Obstruction” means any structure, growth or other object, including a mobile object, which exceeds a limiting height set forth in Sub-section d.

“Precision instrument runway” means a runway having an existing instrument approach procedure utilizing an instrument land system (ILS) or a precision approach radar (PAR). It also means a runway for which a precision approach system is planned and is so indicated on an approved airport layout plan or any other planning document.

“Primary surface” means a surface longitudinally centered on a runway. When the runway has a specially prepared hard surface, the primary surface extends two hundred (200) feet beyond each end of that runway; but when the runway has no specially prepared hard surface, or planned hard surface, the primary surface ends at each end of that runway. The width of the primary surface of a runway will be that width prescribed in Part 77 of the Federal Aviation Regulations for the most precise approach existing or planned for either end of that runway and set forth in Sub-section c. The elevation of any point on the primary surface is the same as the elevation of the nearest point on the runway centerline.

“Runway” is a defined area on an airport prepared for landing and take-off of aircraft along its length.

“Structure” means an object, including a mobile object, constructed or installed by a person, including, but without limitation, buildings, towers, smokestacks, earth formations and overhead transmission lines. Transitional Surfaces. These surfaces extend outward at ninety-degree angles to the runway centerline and the runway centerline extended at a slope of seven feet horizontally for each foot vertically (7:1) from the sides of the primary and approach surfaces to where they intersect the horizontal and conical surfaces. Transitional surfaces for those portions of the precision approach surfaces, which project through and beyond the limits of the conical surface, extend a distance of 5,000 feet measured horizontally from the edge of the approach surface and at ninety-degree angles to the extended runway centerline.

“Tree” means any object of natural growth.

“Utility runway” means a runway that is constructed for and intended to be used by propeller-driven aircraft of twelve thousand five hundred (12,500) pounds maximum gross weight and less.

“Visual runway” means a runway intended solely for the operation of aircraft using visual approach procedures with no straight-in instrument approach procedure.

c. **Airport operations zones.** In order to carry out the provision of this code, there are created and established certain zones which include all of the land lying beneath the approach surfaces, transitional surfaces, horizontal surfaces, and conical surfaces as they apply to the Cheyenne Airport. Such zones are shown on the Cheyenne Airport zoning map and are adopted by reference and declared to be a part of this Title. This map is maintained at the offices of the Airport Board. An area located in more than one of the following zones is considered to be only in the zone with the more restrictive height limitation. The various zones are hereby established and defined as follows:

1. Runway Larger than Utility with a Visibility Minimum Greater than Three-Quarter-Mile Nonprecision Instrument Approach Zone (Runway 12/30). The inner edge of this approach zone coincides with the width of the primary surface and is five hundred (500) feet wide. The approach zone expands outward uniformly to a width of three thousand five hundred (3,500) feet at a horizontal distance of ten thousand (10,000) feet from the primary surface. Its centerline is the continuation of the centerline of the runway.
2. Precision Instrument Runway Approach Zone (Runway 8/26). The inner edge of this approach zone coincides with the width of the primary surface and is one thousand (1,000) feet wide. The approach zone expands outward uniformly to a width of sixteen thousand (16,000) feet at a horizontal distance of fifty thousand (50,000) feet from the primary surface. Its centerline is the continuation of the centerline of the runway.
3. Transitional Zones. The transitional zones are the areas beneath the transitional surfaces.
4. Horizontal Zone. The horizontal zone is established by swinging arcs of ten thousand (10,000) feet radius from the center of each end of the precision instrument runway (Runway 8/26) and connecting the adjacent arcs by drawing lines tangent to those arcs. The horizontal zone does not include the approach and transitional zones.

5. Conical Zone. The conical zone is established as the area that commences at the periphery of the horizontal zone and extends outward and upward therefrom at 20:1 for horizontal distance of four thousand (4,000) feet.

d. **Airport zone height limitations.** Except as otherwise provided in this Title, no structure shall be erected, altered, or maintained and no tree shall be allowed to grow in any zone created by this Title to a height in excess of the applicable height herein established for such zone. Where an area is covered by more than one height limitation, the more restrictive will prevail. The applicable height limitations are established for each of the zones in question as follows:

1. Runway Larger than Utility with a Visibility Minimum Greater than Three-Quarter-Mile Non-Precision Instrument Approach Zone. Runway 12 slopes twenty (20) feet outward for each foot upward (20:1) beginning at the end of and at the same elevation as the primary surface and extending to a horizontal distance of 10,000 feet along the extended runway centerline. Runway 30 slopes thirty-four (34) feet outward for each foot upward (34:1) beginning at the end of and at the same elevation as the primary surface and extending to a horizontal distance of ten thousand (10,000) feet along the extended runway centerline.
2. Precision Instrument Runway Approach Zone. Runway 8 slopes twenty (20) feet outward for each foot upward (20:1) beginning at the end of and at the same elevation as the primary surface and extending to a horizontal distance of ten thousand (10,000) feet along the extended runway centerline. Runway 26 slopes fifty (50) feet outward for each foot upward (50:1) beginning at the end of and at the same elevation as the primary surface and extending to a horizontal distance of ten thousand (10,000) feet along the extended runway centerline; thence slopes upward (40:1) to an additional horizontal distance of forty thousand (40,000) feet along the extended runway centerline.
3. Transitional Zone. The transitional zone slopes seven feet outward for each foot upward (7:1) beginning at the sides of and at the same elevation as the primary surface, and extending to a height of one hundred fifty (150) feet above the airport elevation, which is six thousand one hundred fifty-six (6,156) feet above mean sea level. In addition to the foregoing, there are established height limits sloping seven feet outward

for each foot upward (7:1) beginning at the sides of and at the same elevation as the approach surface, and extending to where they intersect the conical surface. Further, where the precision instrument runway approach zone projects through and beyond the conical zone, there are established height limits sloping seven feet outward for each foot upward (7:1) beginning at the sides of and at the same elevation as the approach surface, and extending to a horizontal distance of five thousand (5,000) feet measured at ninety-degree angles to the extended runway centerline.

4. Horizontal Zone. The horizontal zone is established at one hundred fifty (150) feet above the airport elevation or at a height of six thousand three hundred six (6,306) feet above mean sea level.
5. Conical Zone: The conical zone slopes twenty (20) feet outward for each foot upward (20:1) for four thousand (4,000) feet beginning at the periphery of the horizontal and at one hundred fifty (150) feet above the airport elevation and extending to a height of three hundred fifty (350) feet above the airport elevation.

e. **Airport zone use restrictions.** Airport zone use restrictions are as follows:

1. Notwithstanding any other provision of this Title, no use may be made of land or water within any zone established by this Title in such a manner as to create electrical interference with navigational signals or radio communication between the airport and aircraft, make it difficult for pilots to distinguish between airport lights and others, result in glare in the eyes of pilots using the airport, impair visibility in the vicinity of the airport, create bird strike hazards, or otherwise in any way endanger or interfere with the landing, takeoff, or maneuvering of aircraft intending to use the airport.
2. No place of public assembly shall be permitted in the following portions of the airport approach zones:
 - (a) Within three thousand two hundred (3,200) feet from the end of Runway 8;
 - (b) Within ten thousand (10,000) feet from the end of Runway 26;
 - (c) Within three thousand (3,000) feet from the end of Runway 12;
 - (d) Within three thousand (3,000) feet from the end of Runway 30;
 - (e) Within three thousand four hundred twenty

(3,420) feet from the end of Runway 16;

- (f) Within two thousand eight hundred (2,800) feet from the end of Runway 34. (Zoning Ordinance, Appx. A § 49.050)

f. **Nonconforming uses.** In addition to provisions in Article 1, these special provisions for nonconforming uses will also apply. In the event of a conflict between the provisions, the more restrictive will prevail.

1. Regulations Not Retroactive. The regulations prescribed by this Title shall not be construed to require the removal, lowering, or other change or alteration of any structure or tree not conforming to the regulations as of March 1, 1989 or otherwise interfere with the continuance of nonconforming use. Nothing contained in this section shall require any change in the construction, alteration or intended use of any structure, the construction or alteration of which was begun prior to March 1, 1989 and is diligently prosecuted.
2. Marking and Lighting. Notwithstanding the preceding provision of this section, the owner of any existing nonconforming structure or tree is hereby required to permit the installation, operation and maintenance thereon of such markers and lights as shall be deemed necessary by the Cheyenne Airport Board to indicate to the operators of aircraft in the vicinity of the airport the presence of such airport obstruction. Such markers and lights shall be installed, operated and maintained at the expense of the Cheyenne Airport Board.
3. Nonconforming Uses Abandoned or Destroyed. Whenever the City Engineer Director determines that a nonconforming structure has been abandoned or more than 80 percent torn down, physically deteriorated or decayed, no permit for reconstruction shall be granted that would allow such structure to exceed the applicable height limit or otherwise deviate from the zoning regulations. A nonconforming structure that is abandoned or more than 80 percent deteriorated shall be torn down within one year of the Director's determination, unless a permit for reconstruction is applied for within that one-year period. A nonconforming tree that is more than 80 percent deteriorated or decayed shall be removed by the landowner or the Cheyenne airport board, at the landowner's option, within one month of written notice of that action.

ARTICLE 5

ZONING REGULATIONS

5.6 SPECIAL PURPOSE AND OVERLAY DISTRICTS STANDARDS

- g. **Permit applications--Review.** In order to meet the requirements of Section 5.6, the Director shall refer building permit applications to the Cheyenne Airport Board for review and comment in cases where the proposed buildings or uses may be restricted or limited by the provisions of this Section.

5.6.6 CHR – State Capitol Height Restrictive Overlay District

- a. **Intent and Context.** Special height restrictions shall be required in areas surrounding the State Capitol building. These height restrictions shall be as follows.
- b. **Original City Blocks.** For the purposes of this Section, the land described by blocks shall be construed to be the blocks in the original City plat prior to any replats. Replats of all or portions of these blocks shall also be subject to these height restrictions.
- c. **Building Elevation.** The building height as defined in this Title and the ground elevation above mean sea level shall be determined by the City Engineer and are based on the City of Cheyenne datum.
1. Within the following original City blocks, building elevations shall not exceed six thousand one hundred forty-five (6,145) feet: Blocks: 079, 080, 106, 107, 108, 109, 139, 140, 141, 142, 143, 144, 167, 168, 169, 170, 171, 172, 201, 202, 203, 204, 205, 206.
 2. Within the following original City blocks, building elevations shall not exceed six thousand one hundred fifty-six (6,156) feet: Blocks: 044, 045, 046, 047, 077, 078, 081, 082, 104, 105, 110, 111, 138, 145, 166, 173, 200, 207, 228, 229, 230, 231, 232, 233, 234, 235.
 3. Within the following original City blocks, building elevations shall not exceed six thousand one hundred seventy-four (6,174) feet: Blocks: 016, 017, 018, 019, 043, 048, 076, 083, 103, 112, 137, 146, 165, 174, 199, 208, 227, 236, 261, 262, 263, 264, 265, 266, 267, 268, 269, 270.

5.6.7 Restricted Use Control Area Overlay District (RUCAO)

- a. **Intent and Context.** The restricted use control area overlay (RUCAO) district is intended to establish long-term use restrictions for property in the City on which soil is contaminated. Use restrictions are applied to protect the community from contact with contaminants.

Any modification to any RUCAO, including removal of the RUCAO designation, requires compliance with the Wyoming Environmental Quality Act, Title 35, Article 16 of the Wyoming Statutes and coordination with the Wyoming Department of Environmental Quality (WDEQ).

- b. **Statutory Authority.** The provisions of this Section are based, in part, on Article 16 of the Wyoming Environmental Quality Act, voluntary remediation of contaminated sites.
- c. **Petition Required--Procedure.**
1. The owner of a site who proposes long-term restrictions on the use of the site shall submit a petition, as required by Article 16 (Wyo. Stat. Section 35-11-1609(a)) of the Wyoming Environmental Quality Act, to the Planning and Development Department.
 2. A use control area may be created or modified only upon submission of a petition by the owner of a parcel of real property accepted as a "site" in the WDEQ voluntary remediation program (VRP). The owner must comply with notice and public hearing requirements as provided in subsection d of this section, and shall include only the site.
 3. Upon submission of a petition for long-term use restrictions, the owner shall give written notice of the petition to all surface owners of record of land contiguous to the site. The owner shall also publish notice of the petition and a public hearing once per week for four consecutive weeks in a newspaper of general circulation in Cheyenne, Wyoming. The notice shall identify the property, generally describe the petition and proposed use restrictions, direct that comments may be submitted to the Planning and Development Department, and provide the date, time and place of the Planning Commission meeting at which the petition will be heard and discussed. The public hearing shall be held no sooner than 45 days after the first publication of the notice.
 4. The Planning Commission can modify the petition, if warranted, only during the public hearing, and with WDEQ and site owner concurrence. If the petition is found to be acceptable, the Planning Commission shall recommend the approval of the petition and certify the petition to the City Council. The governing body shall adopt or reject the petition. If the petition is rejected or required to be modified, it shall be returned to the planning commission and owner (who shall confer with the WDEQ) for further review. However, any modification shall be made in accordance with

ARTICLE 5 ZONING REGULATIONS

5.6 SPECIAL PURPOSE AND OVERLAY DISTRICTS STANDARDS

this sub-section including public notice and hearing. If the petition is to be accepted, it shall be approved by ordinance and the overlay designation placed on the official zoning map of the City. The governing body will stipulate and define the specific boundary of the overlay zone, as presented in the petition.

5. The petition shall be finally approved or denied by the governing body within 180 days after the petition has been received by the Planning Commission. The owner and the governing body may agree to extend the time period in which the governing body is to vote upon the petition. The governing body may condition its approval upon the owner's subsequent filing of the determination by the WDEQ director that a remedy can be selected that meets the requirements of Wyo. Stat. Section 35-11-1605 and is consistent with the owner's petition. (Ord. 3598 § 1 (part), 2004)
- d. **Petition--Contents.** Petitions submitted pursuant to sub-section c. shall contain the following documentation:
 1. Introduction: Description of the location and ownership of the site (cross-referenced to an attached map and legal description of the site); size of the site; the source of contamination; and the date the site was accepted into the VRP.
 2. Data: A summary of all data collected, as required by the preliminary remediation agreement, which indicates that the site exceeds cleanup standards necessary to support unrestricted use.
 3. Draft Remedy or Remedies to be Proposed in the Remediation Agreement: Description of the proposed land use for the site and a summary of the remedy or remedies to be used to support the land use. Description of how the remedy will be accomplished and how the outcome of the remedy implementation relates to the request for a RUCAO designation.
 4. Justification for the Use Control Area: Explanation of what would be necessary to make the site suitable for unrestricted use and why it is not feasible to implement this remedy, including an analysis of the amount of effort needed to attain unrestricted use versus the proposed use.
 5. Prohibited Future Uses: A list of the uses which will be prohibited if the RUCAO is established.
 6. Public Notice Requirements: A summary of the public notice procedures to be followed regarding the petition.
 7. Remediation Agreement Acknowledgment: Insertion of the following sentence into the petition: "The site will be subject to a remediation agreement between the owner

and the Wyoming Department of Environmental Quality."

- e. **Amendments and Changes.** Any modification to the RUCAO shall follow the process described in this Section.

5.6.8 Support Services

- a. **Intent.** The Support Services (SS) district is intended for government owned land that is typically accessible to the general public with services supporting the mission of the military and members of the military. This may include educational, recreational, research, retail, office, residential, and industrial uses.
- b. **Applicability.** The SS district is applicable to government owned land in Military/Federal areas of the Comprehensive Plan.
- c. **Context.** This district is most appropriate in areas with access to major regional transportation infrastructure and in close proximity to Francis E. Warren Air Force Base or other federal facilities.
- d. **Lot and Building Standards.** The following lot and building standards shall apply:

TYPE SS: SUPPORT SERVICE DISTRICT LOT AND BUILDING STANDARDS		
Lot Area		n/a
Lot Frontage		n/a
Setbacks (Minimum):	Front	0'
	Side	0'
	Rear	0'
Building Height		n/a
Maximum Coverage		90%

- e. **Permitted Uses.** The uses permitted in the SS district are specified in Table 5-1 as either "permitted" or "administrative" or "conditional."
- f. **Site and Building Design Standards.** The following development standards shall supplement those contained in this code. Wherever possible, and if not exempted, development shall comply with the standards of Article 5 and Article 6 of the UDC, and the standards of this section; however, in the event of a direct conflict, the standards of this section shall govern.
 1. *Parking, Lot Access, and Circulation.* The minimum

ARTICLE 5 ZONING REGULATIONS

5.6 SPECIAL PURPOSE AND OVERLAY DISTRICTS STANDARDS

required Automobile Parking standards of UDC 6.2.4.a shall not apply to property within the SS district.

2. **Sign Allowances.** The following shall supplement the standards of UDC 6.5.4: "For the purposes of the SS district, sign allowances shall be calculated on a per tenant/use basis instead of lot or acreage."
3. **Commercial Building Design Standards.** Development shall comply with the standards of UDC 6.9 with the following modifications:
 - (a) **Detail Features.** Office, research, technology, and military-related development shall be exempt from the Detail Features requirements of UDC 6.9.
 - (b) **Building Materials.** Office, research, technology, and military related development shall be exempt from the Building Materials requirements of UDC 6.9. Commercial and mixed use buildings shall be constructed according to the following material standards as identified in Table 6-21 of UDC 6.9.4.e:
 - (1) **Primary Materials.** All buildings shall have one primary material covering at least 20% of the building façades;
 - (2) **Secondary Materials.** Buildings may have a secondary material covering up to 75% of the façades;
 - (3) **Accent Materials.** Buildings shall have at least on accent material covering at least 5% of the building façade.
 - (c) **Alternatives.** Minor deviations from the standards may be evaluated by the Director to meet the intent of the commercial building design standards of the UDC through an alternative design to allow a site specific plan that is qualitatively equal to or better than the strict application of a design standard specified in this Code. This procedure is not intended as a substitute for a variance or administrative adjustment or a vehicle for relief from standards of this Code. To grant an alternative design, the director shall find either:
 - (1) The proposed alternative design achieves the intent of the subject design standard to the same or better degree than the subject standard; achieves the goals and policies of PlanCheyenne to the same or better degree than the subject standard; and results in benefits to the community that are equivalent to or better than compliance with the subject standard; or
 - (2) The required improvement would be ineffective because of location, topographic,

or site constraints while the alternative design can accommodate site-specific issues.

3. **Landscaping.** Development shall comply with the standards of UDC 6.3, Landscaping Standards, with the following modifications:
 - (a) **Percentage of Living Materials.** Required landscape area, including the internal landscaping area, screening and buffering areas, landscaped setback and parking strips, shall consist of a minimum 65% ground cover by living grass or other plant materials based on mature size of vegetation. The remaining required landscape area may be covered with bark, wood chips, rock, stone, or similar materials.

5.6.9 UU – Urban Use Overlay District

- a. **Intent.** The UU overlay district is intended for Urban and Infill Development. The UU district is intended to transition and step down from the urban core and other urban areas of Cheyenne into the surrounding neighborhoods.
- b. **Applicability.** The UU overlay district is applicable to various lands envisioned for urban development. A base zone district of P, MUB, or MUR must be in place in order for the UU overlay to apply.
- c. **Context.** This district is most appropriate in areas with existing or future urban development patterns.
- d. **Lot and Building Standards.** The following lot and building standards shall apply and replace the lot standards for the underlying district for all uses:

TYPE UU: URBAN USE OVERLAY LOT AND BUILDING STANDARDS		
Lot Area	No minimum or maximum	
Lot Frontage	n/a	
Setbacks:	Front	0' minimum, 10' maximum, or context of surrounding properties
	Side	0' minimum, no maximum side setback 0' minimum, 10' maximum on street side setbacks 5' minimum and 15' maximum on lot lines fronting and adjacent to the Reed Avenue ROW
	Rear	0'
Building Height	Buildings shall not have a pinnacle height that exceeds an elevation of 6,150' in the West Edge District.	
Maximum Coverage	90%, 100% if site provides a street furnishing or projection as listed in 5.6.9.f.4.	

e. **Permitted Uses.** This section shall apply when the underlying zoning district is P, MUR or MUB.

1. *Permitted Uses*

(a) All uses allowed in the underlying zoning district are allowed as indicated in Table 5-1, except as specifically prohibited or allowed in subsections 5.6.9.e.2 below.

2. *Prohibited Uses:*

The following Uses are prohibited in the UU overlay base zone districts:

- (a) Impoundment Yards
- (b) Outdoor Sale
- (c) Automobile Service Repair
- (d) Automobile Service Station – Limited and General

3. *Allowed by Conditional Use in all UU overlay base zone districts:*

- (a) Moderate Industrial

f. **Site and Building Design Standards.** The following development standards shall supplement those contained in this Code. Wherever possible, and if not exempted, development shall comply with the standards of Article 5 and Article 6 of the UDC, and the standards of this section; however, in the event of a direct conflict the standards of this section shall govern.

1. **Parking, Lot Access and Circulation.** *The minimum required Automobile Parking standards of UDC 6.2.4.a shall not apply to property within the UU district.*

(a) **Bicycle Parking.** All new development or changes of use that require a Site Plan per section UDC 2.2.3.b. shall provide 2 bicycle parking spaces per 2,000 square feet of gross floor area.

- (1) Required bicycle parking is permitted in the ROW so long as the parking does not interfere with the 5' required ADA pedestrian zone.
- (2) Applicant will have the ability to provide cash-in-lieu for bicycle parking to the shared biking facilities fund.

2. **Commercial Building Design Standards.**

Development shall comply with the standards of UDC 6.7. with the following modifications:

(a) **West Edge Area.** Properties included in the UU overlay district that fall within the West Edge district, located between 24th Street and the Union Pacific Railroad from north to south and

Carey Avenue to Missile Drive from east to west, shall incorporate the design standards of UDC 6.7; or, as alternative compliance, shall incorporate the design guidelines from Chapter 5 of the 2016 West Edge Area Wide Plan into any development that requires a Site Plan Review per UDC 2.2.3.b.

(b) **Adaptive Reuse.** Adaptive reuse is encouraged in the Urban Use Overlay District. Developments that incorporate an existing structure designated as a significant building in any overlying subarea plan, such as the 2016 West Edge Area Wide Plan, shall receive an exemption from the standards of UDC 6.7. Buildings that receive this exemption shall incorporate design guidelines from the applicable plan.

(c) **Alternatives.** Minor deviations from the standards may be evaluated by the Director to meet the intent of the small scale commercial and mixed-use design standards of the UDC through an alternative design to allow a site-specific plan that is qualitatively equal to or better than the strict application of a design standard specified in this code. This procedure is not intended as a substitute for a variance or administrative adjustment or a vehicle for relief from standards of this Code. To grant an alternative design, the director shall find either:

- (1) The proposed alternative design achieves the intent of the subject design standard to the same or better degree than the subject standard; achieves the goals and policies of PlanCheyenne or the applicable plan to the same or better degree than the subject standard; and results in benefits to the community that are equivalent to or better than compliance with the subject standard; or
- (2) The required improvement would be ineffective because of locational, topographic, or site constraints while the alternative design can accommodate site-specific issues.

3. **Street Trees.** Shall comply with the standards of UDC 6.3.6.

4. **Street Furnishings and Projections into ROW.** May be placed in the ROW so long as the furnishing does not interfere with the 5' required ADA pedestrian zone. All street furnishings and projections into the

ROW shall be shown and approved by the Site Plan process per UDC 2.2.3.b.

- (a) Street furnishings shall include benches, tables, chairs, decorative patio fencing, hosting stands, or other items permitted by the Director.
- (b) Other projections into the ROW may include awnings, patios, or other projections permitted by the Director.

5.7 Specific Use Standards

- 5.7.1 Reserved
- 5.7.2 Home Occupations
- 5.7.3 Accessory Dwelling Units
- 5.7.4 Child Care Uses
- 5.7.5 Assisted Living Facilities
- 5.7.6 Stables, Kennels and Arenas
- 5.7.7 Live / Work Dwellings
- 5.7.8 Automobile Service Stations
- 5.7.9 Bed and Breakfasts
- 5.7.10 Reserved
- 5.7.11 Emergency Shelters
- 5.7.12 Mini Storage

The uses in this section have known or anticipated impacts on adjacent property due to the nature of the operation, scale of the use, or common site and building designs associated with the use. However, these uses may be compatible in various zoning districts if specific standards for the use are followed. Whether these uses are either “permitted”, “administrative”, or “conditional” in any zoning district per Table 5-1, the additional standards in this Section shall apply. If the use is “permitted” in a zoning district these standards shall apply as part of the site plan review; if the use is “administrative” in a zoning district these standards shall apply in association with the Administrative Review criteria in Article 2; if the use is “conditional” in a zoning district these standards shall apply in addition to the discretionary Conditional Review criteria in Article 2.

5.7.1 [Reserved]

5.7.2 Home Occupations

In districts where home occupations are allowed, they shall meet the following standards in addition to all other lot and building standards for the district.

- a. Home occupations include, but are not limited to, arts and crafts-making, tailoring or seamstress services, one or two-person professional offices (medical, insurance, law, etc.), music instruction and wholesale/catalogue sales.
- b. Home occupations are intended to allow limited business activity from the home but shall not alter the character of the neighborhood.
- c. Additional off-street parking may be required for the home occupation business if more than three clients per day are expected to visit the business. No additional parking

ARTICLE 5

ZONING REGULATIONS

5.7 SPECIFIC USE STANDARDS

spaces shall be provided in the front yard setback (or within the side yard setback if the property is a corner lot). Where needed additional parking would alter the character of the neighborhood the home occupation shall be prohibited.

- d. There shall be no offensive noise, vibration, smoke, dust, odors, heat or glare noticeable at or beyond the property line.
- e. No exterior storage is permitted.
- f. Signage will be limited to one sign not more than three square feet in area per home.
- g. No retail sales are permitted from the site other than incidental sales related to services provided.
- h. Not more than one employee or co-worker other than the permanent resident(s) can work from the site.
- i. An "in-home" business operating from a residential dwelling within shall be registered in the home occupation data base, administered through the City Planning and Development Department.
- j. Specific Exclusions. The following businesses shall not be allowed as home occupations:
 - 1. Auto body or mechanical repair, to include any modification, assembly or painting of motor vehicles and repair of internal combustion engines;
 - 2. Massage parlors/technicians;
 - 3. Beauty parlors, nail salons and barber shops;
 - 4. Animal grooming salons and boarding kennels;
 - 5. Body piercing/body art/tattoo art.

5.7.3 Accessory Dwelling Units

In districts where accessory dwelling units are allowed as permitted, administrative or conditional uses, they shall meet the following standards in addition to all other lot and building standards for the district.

- a. The accessory dwelling unit may be in the principal building or any permitted accessory building, however all applicable lot and building type standards for the district shall apply.
- b. Only one accessory dwelling unit is permitted per detached one-unit dwelling lot in any zoning district where accessory dwellings are allowed as permitted, administrative or conditional uses. Accessory dwelling units are prohibited on lots with multi-dwelling buildings, attached dwellings or semi-attached dwellings.
- c. The property owner must occupy either the principal unit or the accessory dwelling unit as their permanent residence.
- d. After approval by the Development Office of an accessory dwelling unit pursuant to subsection (b) of this section, the property owner will record with the Laramie County

real estate office a "Notice of ADU Regulations" that shall contain a legal description of the subject property. The "Notice of ADU Regulations" shall be in a form approved by the Development Office prior to filling.

- e. In no case shall an accessory dwelling unit be more than 40 percent of the principal dwelling unit up to a maximum of 1,200 square feet. This limitation is in addition to all other lot and building standards applicable in the district. Square footage calculations, as contained herein, exclude any related garage, porch, or similar area.
- f. The unit size limitations shall not apply to basement apartments. The size of a basement apartment may occupy the entire floor area of the existing basement.
- g. The accessory dwelling unit shall not include any design elements on principal or accessory buildings that alter the character of the lot, building type or district in general.
- h. An accessory building used for an Accessory Dwelling Unit shall be designed to preserve or complement the architectural design, style and appearance of the principal building.
- i. One off-street parking space shall be provided in addition to that which is required for the principal dwelling, and it shall be located on a discrete portion of the lot.

5.7.4 Child Care Uses

In districts where child care uses are allowed, they shall meet the following standards in addition to all other lot and building standards for the district.

- a. Family Child Care Home (FCCH)
 - 1. Shall be located within the primary residence of the owner.
 - 2. No more than 10 children shall be permitted.
 - 3. All requirements of the Wyoming Department of Family Services shall be met.
- b. Family Child Care Center (FCCC)
 - 1. Shall be located within the primary residence of the owner.
 - 2. No more than 15 children shall be permitted.
 - 3. All requirements of the Wyoming Department of Family Services shall be met.
 - 4. Parking will be required per Section 6.2.4, Table 6-2.
- c. Child Care Center (CCC)
 - 1. Shall not be located within a residence.
 - 2. All requirements of the Wyoming Department of Family Services shall be met.
 - 3. Parking will be required per Section 6.2.4, Table 6-2.
- d. Child Care provided as an accessory/secondary use to a commercial or industrial business is permitted in any zone

district and must meet all requirements of the Wyoming Department of Family Services.

Table 5-3: Reserved

5.7.5 Assisted Living Facilities, Nursing Homes, and Group Housing

In districts where Assisted Living Facilities, Nursing Homes, or Group Housing are allowed, they shall meet the following standards in addition to all other lot and building standards for the district.

- a. Assisted Living Facilities and Nursing Homes shall be certified by the State of Wyoming. The Wyoming Department of Health, Health Facilities Program, is the duly authorized licensing agency for assisted living facilities pursuant to the state of Wyoming Assisted Living Facilities Rules and Regulations.
- b. Assisted Living Facilities and Nursing Homes located in commercial or mixed-use zones shall provide one signed loading and unloading zone on the same site.
- c. Manufactured housing shall not be utilized for assisted living facilities per state of Wyoming Rules and Regulations.
- d. Group Housing shall be licensed or certified by the appropriate State of Wyoming Department.
- e. Group Housing and Assisted Living Facilities/Nursing Homes must meet fire and building codes adopted by the City of Cheyenne.

5.7.6 Stables, Kennels and Arenas

In districts where stables, kennels and arenas are allowed, they shall meet the following standards in addition to all other lot and building standards for the district.

- a. The site shall be certified by the city-county health unit as not creating a health hazard.
- b. The distance between livestock (in barns, sheds, loafing areas and pastures) and domestic wells shall follow Department of Environmental Quality (DEQ) and city-county health unit requirements.
- c. Adequate on-site parking shall be provided for maximum use of the facility.
- d. Offal/excretion shall be removed on a regular basis so as not to attract flies and create a health hazard.

5.7.7 Live/Work Dwellings

In districts where live/work dwellings are allowed, they shall meet the following standards in addition to all other lot and building standards for this lot and building type established for the NB zoning district.

- a. A live/work building shall have two clearly distinct areas, the living area and the non-living area. These areas may be connected by a doorway but shall have the ability to be separated by a closed and secure door. Each area shall separately and independently meet the required building codes applicable to the intended use for that portion of the building.
- b. The living area of the unit shall represent between 50% and 75% of the total floor area.
 1. The living area shall be at least 700 square feet.
 2. The non-living area shall not exceed 1,500 square feet.
- c. Occupational or vocational uses allowed in the non-living portion may be any non-residential use allowed in the zoning district as either a permitted use or a home occupation.
- d. The facility shall be designed and operated so that no more than 2 non-resident staff shall be at the facility at any one time.
- e. The occupant of both the living area and the non-living area shall be the same individual or group of individuals at all times.
- f. Required parking shall be based on the greater of the parking required for the non-living area or the living area.
- g. The street-front portion of the building shall be designed to match the adjacent street front of buildings on the same side of the block and street front of buildings on the opposite block face.
 1. Where the street front of buildings across the street or adjacent to the unit are retail or service uses, the street front portion of the unit shall be the non-living area and subject to the Small-scale Commercial and Mixed-use Design Standards in Section 6.7.
 2. Where the street front of buildings across the street or adjacent to the unit are residential, the street-front portion of the unit shall be the living area and subject to the Residential Design Standards in Section 6.6.
 3. Where the street front of buildings across the street and adjacent to the unit are a mix or residential and service or retail uses, the unit shall be designed to be compatible to the most prevailing pattern on the block. In determining the most prevailing pattern, immediately adjacent buildings shall be considered more heavily.

5.7.8 Automobile Service Stations

In districts where automobile service stations are allowed, they shall meet the following standards in addition to all other lot and building standards for the district.

- a. **Building Designs.** In districts that require a specific building frontage, build-to-line or other building design standards, Automobile service stations are granted exceptions to those standards provided the following alternative standards are met:
 - 1. All buildings shall have at least one street-facing façade that includes a primary building entrance.
 - 2. At least 60% of any building facade within 30' of the right-of-way shall be openings including windows and doors.
 - 3. Any building that is not constructed according to the required build-to-line shall have an alternative streetscape edge shall occur along at least 60% of all right-of-way frontage. The defined edge may include any combination of the following:
 - (a) Any portion of the building façade built according to the required build-to-line, meets the general building design standards for the district;
 - (b) A 2.5 foot to 4 foot high decorative masonry wall or ornamental fence, matching the materials and architecture of the building;
 - (c) A 2.5 foot to 4 foot dense vegetative screen;
 - (d) On corner lots, the first 20' in each direction from the corner of the lot shall have a defined streetscape edge, subject to any site distance requirements at the intersection.
- b. **Landscape and Screening Enhancements.** In addition to other provisions of Section 6.3, any Automobile Service station within 200' of a residentially zoned lot shall have a 10% area increase and a 10% plant material increase, allocated to buffering the site from residential uses. An exception to this requirement may be granted by Administrative Adjustment according to the procedures and criteria in Article 2, provided an alternative transition suitable to the context of the neighborhood and site is designed.

5.7.9 Bed and Breakfasts

In any residential zoning districts where Bed and Breakfasts are allowed, they shall meet the following standards in addition to all other lot and building standards for the district:

- a. Bed and breakfasts shall be accessory to a principal dwelling unit.
- b. In the all districts except the AG, AR, and RR zoning districts, bed and breakfasts should be located only on lots within 660 feet of an Activity Center or similar neighborhood commercial or mixed-use environment, measured along a dedicated pedestrian route.
- c. Bed and breakfasts shall contain no more than 6 guest rooms.
- d. The owner of the business shall maintain a permanent residence in either the principle dwelling unit or accessory dwelling unit.
- e. Guests must pay on the basis of a daily rental rate, and must limit their stay to 14 consecutive days.
- f. Guests rooms are to be limited to the purpose of sleeping and kitchen or cooking facilities shall not be allowed in guest rooms.
- g. Receptions or meetings of groups are prohibited.
- h. The facility shall require no more than 2 non-resident staff to be at the facility at any one time.
- i. One off-street parking space shall be provided per 2 guest rooms in addition to that which is required for the principal dwelling, and they shall be located on a discrete portion of the lot.
- j. The bed and breakfast shall not include any design elements on principal or accessory buildings that alter the character of the lot, building type or district in general.

5.7.10 [RESERVED]

5.7.11 Emergency Shelter

In districts where emergency shelters are allowed, they shall meet the following standards in addition to all other lot and building standards for the district.

- a. An Emergency Shelter shall not be located within five hundred (500) feet of any LR (Low-Density Residential), MR (Medium Density Residential), HR (Highdensity Residential), NR-1 (Neighborhood Residential - Moderate Density), NR-2 (Neighborhood Residential - Medium Density), NR-3 (Neighborhood Residential - High Density), and MUR (Mixed-Use Residential Emphasis) zoned property.

Measurement shall be made in a straight line, without regard to intervening structures or streets, from the nearest portion of the building, structure, or site associated with the use to the nearest property line.

5.7.12 Mini Storage

In districts where Mini Storage is permissible by conditional discretionary review the following additional standards shall apply:

- a. In MR, HR, MUR, and MUB Districts:
 - 1. The minimum lot area shall be one (1) acre.
 - 2. The use shall be adjacent to a right-of -way with a functional classification of a Major Collector, Minor Arterial, or Principal Arterial.
 - 3. A Level 1 buffer shall apply to all property lines in accordance with UDC 6.3.5.b.
 - 4. Parking areas for the storage of vehicles, trailers, recreational vehicles, boats, snow mobiles and other similar items shall not exceed twenty-five (25) percent or one half (1/2) acre of the lot area, whichever is more restrictive. A solid fence, wall, or similar design element is required to screen any portion of the lot dedicated for this purpose from neighboring residential properties.
- b. In the CBD District:
 - 1. No parking area for the storage of vehicles, trailers, recreational vehicles, boats, snow mobiles and other similar items shall be permitted.
 - 2. All storage units shall be internally accessed within a building. No unit shall have direct access to the exterior of the building.
 - 3. Parking and loading areas shall be located behind the principal building and shall not be visible from adjacent street rights-of-way.
 - 4. Structures shall be setback no more than ten (10) feet from any property line adjacent to a street right-of-way.
 - 5. All developments shall meet the Small Scale Commercial and Mixed-use Design Standards of UDC Chapter 6. 7.

5.8 Supplemental Provisions

- 5.8.1 Wireless Telecommunication Services
- 5.8.2 Manufactured Homes and Parks
- 5.8.3 Drive-through facilities
- 5.8.4 Fences
- 5.8.5 Refuse Containers
- 5.8.6 Outdoor Storage
- 5.8.7 Oil and Gas Support Service
- 5.8.8 Accessory Buildings

The standards in this section have broad application across a number of zoning districts, and to a number of uses or site conditions within zoning districts. The standards in this section are supplemental to all other standards, and apply in addition to any other standards applicable within the zoning district.

5.8.1 Wireless Communication Facilities

a. Purpose.

1. The purpose of this Section is to establish general guidelines for siting traditional wireless communications towers and newer small wireless facilities within zone districts and rights-of-way. The goals of this Section are to: (1) protect residential areas and land uses from potential impacts of towers; (2) encourage the location of towers where they will best serve citizens and first responders; (3) strongly encourage the joint use of new and existing tower sites as a primary option rather than construction of additional single-use towers; (4) encourage users of towers to locate them, to the extent possible, in areas where the impact on the community is minimal; and (5) facilitate the deployment of small wireless facilities in the rights-of-way.
2. It is not the intent or purpose of this Section to prohibit or have the effect of prohibiting the deployment of wireless communications facilities, to regulate the placement, installation, or modification of such facilities on the basis of radio frequency emissions, or to unreasonably discriminate among wireless communications providers who provide functionally equivalent services. Nothing contained in this Section is intended or has the purpose to preempt any State or federal law applicable to wireless communications facilities.

b. Definitions.

As used in this Section, the following terms shall have the meanings set forth below:

Antenna. Any transmitting or receiving communication device that sends or receives electromagnetic waves, digital signals, analog signals, radio frequencies (excluding radar signals), wireless telecommunications signals or other communication signals.

Antenna array. A single or group of antenna elements, not including small wireless facility antennas, and associated mounting hardware, transmission lines, remote radio units, or other appurtenances which share a common attachment device such as a mounting frame or mounting support structure for the sole purpose of transmitting or receiving wireless communication signals.

Applicant. Any person engaged in the business of providing wireless communication services or the wireless communications infrastructure required for wireless communication services and who submits an application.

Backhaul network. The physical telephone or fiber optic lines or microwave dishes that connect a provider's towers or cell sites to other cell sites or one or more cellular telephone switching offices or long-distance providers, or the public switched telephone network.

Base station. A structure or equipment at a fixed location that enables FCC-licensed or authorized wireless communications between user equipment and a communications network. The definition of Base Station does not include or encompass a tower, or any accessory equipment associated with a tower. A base station includes, without limitation:

- A. Equipment used or contemplated to be used to support wireless communications services such as private, broadcast, and public safety services, as well as unlicensed wireless services and fixed wireless services such as microwave backhaul that, at the time the relevant application is filed with the City under this Section, has been reviewed and approved under the applicable zoning or siting process, or under another state or local regulatory review process, even if the structure was not built for the sole or primary purpose of providing such support; and
- B. Radio transceivers, antennas, coaxial or fiber-optic cable, regular and backup power supplies, and

comparable equipment, regardless of technological configuration (including Distributed Antenna Systems (“DAS”) and small wireless facilities).

Collocation. The mounting or installation of equipment on an existing tower, building, or structure for the purpose of transmitting or receiving radio frequency signals for communications purposes.

Distributed Antenna System or DAS. A network consisting of transceiver equipment at a central hub site to support multiple antenna locations throughout the desired coverage area.

Eligible Facilities Request. Any request for modification of an existing tower or base station that does not substantially change the physical dimensions involving:

- A. collocation of new equipment,
- B. removal of equipment, or
- C. replacement of equipment.

Eligible support structure. Any tower or base station as defined in this Section, provided that it is existing at the time the relevant application is filed with the City under this Section.

Existing. A tower or base station that has been reviewed and approved under the applicable zoning or siting process, or under another State or local regulatory review process, provided that a tower that has not been reviewed and approved because it was not in a zoned area when it was built, but was lawfully constructed, is existing for purposes of this definition.

FAA. The Federal Aviation Administration.

FCC. The Federal Communications Commission.

Macro cell. An antenna or antennas mounted on or in a tower, ground-based mast, rooftops or structures, at a height that provides coverage to the surrounding area.

Micro wireless facility. A small wireless facility that is less than 24 inches in length, 15 inches in width, and 12 inches in height and that has an exterior antenna less than 11 inches in length.

Pole. A pole or similar structure that is or may be used in whole or in part by or for wireline communications, electric distribution, lighting, signage, or a similar function, or for the collocation of small wireless facilities.

Replacement pole. Replacing an existing pole, with a pole of similar height, design and color to accommodate the collocation of a small wireless facility.

Site. In relation to a tower that is not in the public right-of-way, the current boundaries of the leased or owned property surrounding the tower and any access or utility easements currently related to the site. In relation to support structures other than towers, site means an area in proximity to the structure and to other transmission equipment already deployed on the ground.

Small wireless facility(ies). Facilities that meet the following conditions: (1) the facilities -- (i) are mounted on structures fifty (50) feet or less in height including their antennas, or (ii) are mounted on structures no more than ten percent (10%) taller than other adjacent structures, or (iii) do not extend existing structures on which they are located to a height of more than fifty (50) feet or by more than ten percent (10%), whichever is greater; (2) each antenna associated with the deployment, excluding associated antenna equipment, is no more than three (3) cubic feet in volume; (3) all other wireless equipment associated with the structure, including the wireless equipment associated with the antenna and any pre-existing associated equipment on the structure, is no more than twenty eight (28) cubic feet in volume; (4) the facilities do not require antenna structure registration under federal law; (5) the facilities are not located on Tribal land as defined under federal law; and (6) the facilities do not result in human exposure to radiofrequency radiation in excess of the applicable safety standards specified under federal law. The following types of associated ancillary equipment are not included in the calculation of equipment volume: electric meter, concealment elements, telecommunications demarcation box, grounding equipment, power transfer switch, cut-off switch, and vertical cable runs for the connection of power and other services.

Stealth design. A design that minimizes the visual impact of wireless communication facilities by camouflaging, disguising, screening or blending them into the surrounding environment. Examples of stealth design include but are not limited to facilities disguised as trees (monopines), flagpoles, utility and light poles, bell towers, clock towers, ball field lights and architecturally screened roof-mounted antennas or flush-mounted antennas that are either painted to match or enclosed in an architecturally-applicable box.

Substantial change. A significant change as defined in the Code of Federal Regulations (Title 47 Part 1 Subpart U § 1.6100(b)(7)).

Support structure(s). A structure designed to support small wireless facilities including, but not limited to billboards and other freestanding self-supporting structures.

Tower. Any structure built for the sole or primary purpose of supporting any FCC-licensed or authorized antennas and their associated facilities, including structures that are constructed for wireless communication services including, but not limited to, private, broadcast, and public safety services, as well as unlicensed wireless services and fixed wireless services such as microwave backhaul and the associated site.

Tower height. The vertical distance measured from the base of the tower structure at grade to the highest point of the structure including the antenna. A lightning rod, not to exceed ten (10) feet in height, shall not be included within tower height.

Traffic control devices. Traffic control devices shall be defined as all signs, signals, markings, and other devices used to regulate, warn, or guide traffic, placed on, over, or adjacent to a street, highway, pedestrian facility, bikeway, or private road open to public travel by authority of a public agency or official having jurisdiction, or, in the case of a private road, by authority of the private owner or private official having jurisdiction, as defined in the latest edition of the Manual On Uniform Traffic Control Devices (MUTCD).

Transmission equipment. Equipment that facilitates transmission for any FCC-licensed or authorized wireless communication service, including, but not limited to, radio transceivers, antennas, microwave dishes, coaxial or fiber-optic cable, and regular and backup power supplies. The term includes equipment associated with wireless communication services including, but not limited to, private, broadcast, and public safety services, as well as unlicensed wireless services and fixed wireless services such as microwave backhaul.

Wireless communication facilities or WCF. An unstaffed facility or equipment for the transmission or reception of radio frequency (RF) signals, wireless communications, or other signals for commercial communications purposes, typically consisting of a group of antennas, a tower or base station, transmission cables and other transmission equipment, backup power supplies, power transfer

switches, cut-off switches, electric meters, coaxial cables, fiber optic cables, wires, telecommunications demarcation boxes and related materials and equipment cabinets, and including small wireless facilities.

c. **Applicability.**

1. *New Towers, Antennas, DAS, and Small Wireless Facilities.* All new towers, antennas, DAS, and small wireless facilities shall be subject to these regulations.
 - (a) New towers exceeding the maximum height limitation in LR, MR, HR, N1, and N3 zone districts and towers exceeding 50' in non-residential districts, including those for small wireless facilities, require conditional use approvals.
 - (b) New antenna arrays meeting the requirements of Section 5.8.1.f.17 below are permitted with a building permit.
 - (c) Small wireless facilities are permitted in any zone pursuant to Section 5.8.1.e.
 - (d) Antennas attached to utility poles, light poles, traffic control devices, or similar items in the public rights-of-way are subject to approval by the City Engineer in accordance with UDC 1.2.2.b. 10' above the highest point of the pole structure and may be installed when permitted by the pole owner's franchise or by amendment to the pole owner's franchise and consent of the City upon payment of reasonable compensation for use of the rights-of-way.
2. *Exempt Facilities.* The following are exempt from this Section:
 - (a) FCC licensed amateur (ham) radio facilities;
 - (b) Satellite earth stations, dishes, or antennas used for private television reception not exceeding one (1) meter or 3.28 feet in diameter;
 - (c) A WCF installed upon the declaration of a state of emergency by the federal, state or local government, or a written determination of public necessity by the City; except that such facility must comply with all federal and State requirements. The WCF shall be exempt from the provisions of this Section for up to one month after the duration of the state of emergency;
 - (d) A temporary, commercial WCF installed for providing coverage of a special event such as news coverage or sporting event, subject to approval by the City. The WCF shall be exempt from the provisions of this Section for up to two weeks before and one week after the duration of the special event;

- (e) Other temporary, commercial WCFs installed for a period of up to thirty (30) days, subject to the City's discretion; provided that such temporary WCF will comply with applicable setbacks and height requirements;
 - (f) Antennas attached to existing structures (such as commercial buildings, houses or apartments) for Internet purposes and used solely by occupants of the building to which the antennas are attached as long as the height limitations of the zoning district are not exceeded, and the antenna design is satisfactory to the City; and
 - (g) Routine maintenance and repair of WCFs.
- d. **Use Categories.**
1. *Use by Right.*
 - (a) *General.* The uses listed in this Section are uses by right in any zone, but a site plan and any necessary legal instruments including, but not limited to, a lease agreement, are required.
 - (b) *County or City Property.* The following use is specifically permitted:
 - (1) Antennas located on Laramie County property within the City or on City property (excluding public rights-of-way), provided a lease authorizing the facility has been approved by the County or the City respectively.
 2. *Administrative and Conditional Use Approval.*
 - (a) *General.* In addition to the review procedures and approval criteria of Sections 2.2.5 (Conditional Use Approval), 2.2.6 (Administrative Use Approval), and the General Requirements of Section 5.8.1.f, the following provisions shall govern the issuance of administrative approvals.
 - (1) Each applicant for administrative approval shall provide the information set forth in this Section. A fee is required and shall be set by the City.
 - (2) Administrative Review Process (Administrative Review). The Director shall review the application and determine if the proposed use complies with this Section. For applications involving proposed uses within a public right-of-way, the Director shall obtain the approval of the City Engineer prior to approval of the application.
 - (3) In connection with any such Administrative Review, the City may, in order to encourage shared use, administratively waive any zoning district setback requirements or separation distances, if any, between towers by up to fifty (50) percent. Setback requirements shall not apply within or adjacent to a right-of-way.
- (4) In connection with any Administrative Review and approval, the City may, in order to encourage the use of monopoles, administratively allow the on-site upgrade or reconstruction of an existing tower to monopole construction.
 - (5) No new macro cell tower application shall be processed unless the applicant has discussed the proposal with the Director prior to submission to review the feasibility of using an existing tower or structure. The applicant must demonstrate that there is no current facility that can reasonably accommodate the applicant's proposed antenna.
- (b) *List of Administratively Approved Uses.* The following uses may be approved (for uses which do not qualify as a use by right or require Board Approval) by Administrative Review:
- (1) Locating a tower, including the placement of additional buildings or other supporting equipment used in connection with said tower in the heavy industrial district, provided the tower height does not exceed one hundred (100) feet;
 - (2) Locating antennas on existing structures or towers consistent with the terms of subsections i. and ii. below:
 - i. Antennas on Buildings. Any antenna which is not attached to a tower may be approved by the development office as an accessory use to any commercial, industrial, professional, institutional, or multifamily structure of eight or more dwelling units, provided the antenna does not extend more than ten (10) feet above the highest point of the structure.
 - ii. Antennas on Existing Towers or Reconstruction of an Existing Tower. An antenna which is attached to an existing tower may be approved by the development office. Reconstruction of a tower which provides for future collocation of antennas shall take precedence over the construction of new towers, provided such collocation

or reconstruction is accomplished in a manner consistent with the following:

(A) A tower which is modified or reconstructed to accommodate the collocation, unless determined through Administrative Review reconstruction as a monopole is allowed.

(B) Height:

- (1) An existing tower may be modified or rebuilt to a taller height, not to exceed forty (40) feet over the tower's existing height, to accommodate the collocation of additional antennas.
- (2) The height change referred to in this Section may only occur one time per tower.
- (3) The additional height referred to in this Section shall not require additional setback distance separation. The tower's prior height shall be used to calculate such distance separations.

(C) On-site location:

- (1) A tower which is being rebuilt to accommodate the collocation of an additional antenna may be moved on-site within fifty (50) feet of its existing location.
- (2) After the new tower is built to accommodate collocation, only one tower may remain on the site, and the original tower shall be removed within ninety (90) days of completion of the new tower.
- (3) The on-site relocation of a tower which does not comply with the separation distances to residential units or residentially zoned lands shall only be permitted when approved by the Board.

(3) *New Towers in Nonresidential Zoning Districts.* Locating any new tower in a nonresidential zoning district, provided a Wyoming licensed professional engineer certifies the tower can structurally accommodate the number of shared users proposed by the applicant and the tower meets the height and usage criteria of the respective zone.

(4) Locating any alternative tower in a zoning district that, in the judgment of the Director, is in conformity with this Section.

(5) Installing a micro wireless facility through the use of low-powered transmitters/receivers attached to existing wireline systems, such as conventional cable or telephone strand.

(6) Modification of an existing tower or base station pursuant to an Eligible Facilities Request and in accordance with the standards set forth in this Section.

(7) Installing small wireless facilities, poles and replacement poles.

(c) *List of Conditional Use Approvals.* New macro cell towers located in the following residential zone districts: LR, MR, HR, NR-1, NR-2, and NR-3 shall require Board approval in compliance with Sections 2.2.4 (Conditional Use Approval) and 5.8.1.g.3 (*Factors Considered in Granting Conditional Use Approvals for Towers*).

e. ***Distributed Antenna Systems and Small Wireless Facilities.***

1. Distributed antenna systems and small wireless facilities are permitted uses subject to Administrative Review and the following standards:

(a) Facilities shall be a permitted use subject to administrative approval in all zoning districts and public rights-of-way as long as the pole or tower does not exceed the maximum height limit of the affected zoning district.

(b) Monopoles and replacement poles shall be a permitted use subject to administrative approval in utility and public rights-of-way, up to the greater of forty (40) feet or ten (10) percent higher than any pole in the rights-of-way which is within five hundred (500) feet.

(c) Facilities may be located on a support structure, replacement pole, or other pole located in public or utility rights-of-way.

- (d) Facilities shall not extend eight (8) feet above buildings, existing structures, or other similar structures. Facilities shall not extend more than ten (10) feet above poles or support structures.
 - (e) The height of any free-standing facility shall not exceed the greater of forty (40) feet or ten (10) percent higher than poles in the rights-of-way which are within five hundred (500) feet.
 - (f) Facilities that use the structure of a utility pole for support are permitted under this Section. Such poles may extend up to ten (10) feet above the height of the utility pole.
 - (g) Facilities and monopoles and replacement poles in the right-of-way shall be exempt from all setback requirements.
 - (h) Facilities shall comply with all applicable codes.
 - (i) Facilities and equipment shall, to the extent possible, use materials, colors, textures, screening, undergrounding, or other design options that will blend the facility into the surrounding natural setting or built environment. Design, materials, and colors of facilities shall be compatible with the surrounding environment. Designs shall be compatible with structures and vegetation located in the public right-of-way and on adjacent parcels. These aesthetic requirements are reasonable, objective, non-discriminatory and published per this ordinance.
2. *Application Requirements.* An application for a facility as a permitted use subject to Administrative Review shall contain the following:
 - (a) The signature of the authorized agent of the property owner, or the owner of the existing structure, support structure, pole or replacement pole.
 - (b) Separate pole attachment agreements with the pole owner, if the applicant seeks to install an attachment on another party's pole.
 - (c) A map showing the intended location(s) of the facility(ies), representative pictures of the intended facilities, and stamped engineering and construction plans and drawings.
 - (d) A statement certifying compliance with all non-discretionary structural, electrical, energy, building, safety and other applicable codes.
 3. *Permitted Uses.* Facilities are permitted uses in all zones, regardless of siting preferences identified herein, provided the applicant complies with all federal laws (such as the Americans with Disabilities Act), State laws and requirements, and stealth requirements of this Section.
 4. *Batched Applications.* A single administrative approval application may be used for multiple distributed antennas that are part of a larger overall DAS network. A single administrative approval application may also be used for multiple sites for small wireless facilities. A single license agreement may be used for multiple node locations in DAS and/or small wireless facility networks.
- f. **General Requirements.**
1. *Principal or Accessory Use.* DAS and small wireless facilities may be considered either principal or accessory uses. A different existing use of an existing structure on the same lot shall not preclude the installation of an antenna or tower on such lot.
 2. *Lot Size.* The dimensions of the entire lot shall control for purposes of measurements, even though the antennas or towers may be located on leased parcels within a lot.
 3. *Lighting.* Towers may not be artificially lighted, unless required by public safety, the FAA or other applicable authority.
 4. *State or Federal Requirements.* All towers and antennas must meet current standards and regulations of the FAA, FCC and any other agency of the local, state or federal government with the authority to regulate towers and antennas.
 5. *Building Codes; Industry Standards.* To ensure the structural integrity of towers, the owner of a tower shall ensure that the tower is maintained in compliance with applicable state and local building code standards and the then applicable Industry standards for towers.
 6. *Permit or License.* Owners and operators of towers and antennas shall certify that any permit or license required for the construction and operation of a wireless communication system in the City has been obtained.
 7. *Public Notice.* For purposes of this Section, any application for a WCF, including small wireless facilities, variance, exception, or appeal of a request for approval requires public notice to all adjoining property owners and all owners of surrounding properties as required by the Unified Development Code.
 8. *Multiple Antennas/Towers.* Users are encouraged to submit a single application for approval of multiple towers and/or antenna sites. An application for multiple sites will be given priority in the review process.

9. *Equipment Cabinets.*
- (a) Compliance. The equipment cabinets shall comply with all applicable building codes and zoning requirements. The site plan submitted with an application for administrative approval shall include the equipment cabinet, if any.
 - (b) Location. The equipment cabinet or structure used in association with antennas shall be located in accordance with the site plan to be approved by Administrative Review.
 - (c) Minimum Requirements. The related equipment structure shall be located in accordance with the minimum requirements of the zoning district in which it is located. A site plan application, any other applicable applications, and associated fees are required.
10. *Inventory of Existing Sites.* Not more than one time every five (5) years, each applicant for a macro cell shall provide to the Director and City Engineer an inventory of the wireless carrier's existing towers, antennas, or sites approved for towers or antennas, that are either within the jurisdiction of the City or within one mile of the border thereof, including specific information about the location and height. The Director and City Engineer may share such information with other applicants applying for approvals under this Section or other organizations seeking to locate antennas within the jurisdiction of the City, provided, however, that the Director and City Engineer are not, by sharing such information, in any way representing or warranting that such sites are available or suitable.
11. *Color.* To the extent feasible, the antenna array shall be placed and colored to blend into the architectural detail and coloring of the host structure. Towers shall be painted a color that best allows it to blend into the surroundings. The use of grays, blues, greens, dark bronze, browns or other site-specific colors may be appropriate; however, each case should be evaluated individually.
12. *Site Development Standards.* All wireless communication facilities shall be required to obtain required approvals and shall be subject to the site development standards prescribed herein. A site development plan, at minimum, shall contain the following information:
- (a) Construction drawings, stamped by a professional engineer, showing the proposed method of installation;
 - (b) The manufacturer's recommended installations, if any;
 - (c) A diagram to scale showing the location of the wireless communication facility, property and setback lines, easements, power lines, all structures, and the required landscaping; and
 - (d) Photo simulations that include to-scale visual simulations that show unobstructed before-and-after construction daytime and clear-weather views from at least four angles, together with a map that shows the location of each view, including all equipment and cabling.
13. *Signs.* No facilities may bear any signage other than that required by law or expressly permitted or required by the City, except if such signage functions in a manner designed to conceal the facility and is aesthetically consistent with its context.
14. *Visual Impact.* All WCFs in residential districts and within two hundred feet (200') of residential districts or the Greenway shall be sited and designed to minimize adverse visual impacts on surrounding properties and the traveling public to the greatest extent reasonably possible, consistent with the proper functioning of the WCF. Such WCFs and equipment enclosures shall be integrated through location and design to blend in with the existing characteristics of the site. Such WCFs shall also be designed to either resemble the surrounding landscape and other natural features where located in proximity to natural surroundings, or be compatible with the built environment, through matching and complementary existing structures and specific design considerations such as architectural designs, height, scale, color and texture or be consistent with other uses and improvements permitted in the relevant zone.
15. *Use of Stealth Design.* The applicant shall use stealth design to the maximum extent feasible unless otherwise approved by the City. Stealth and concealment techniques must be appropriate given the proposed location, design, visual environment, and nearby uses, structures, and natural features. Stealth design shall be designed and constructed to substantially conform to surrounding building designs or natural settings, so as to be visually unobtrusive. Stealth design that relies on screening wireless communication facilities in order to reduce visual impact must screen all substantial portions of the facility from view.

16. *Building-mounted WCFs.*

- (a) All transmission equipment shall be concealed within existing architectural features to the maximum extent feasible. Any new architectural features proposed to conceal the transmission equipment shall be designed to mimic the existing underlying structure, shall be as proportional as possible to the existing underlying structure or conform to the underlying use and shall use materials in similar quality, finish, color and texture as the existing underlying structure.
- (b) All roof-mounted transmission equipment shall be set back from all roof edges to the maximum extent feasible consistent with the need for "line-of-sight" transmission and reception of signals.
- (c) Antenna arrays and supporting transmission equipment shall be installed so as to camouflage, disguise or conceal them to make them closely compatible with and blend into the setting or host structure.

17. *Antenna Arrays.* Wireless communication antenna arrays are permitted, subject to review and approval, in any zone as long as they are located upon an existing structure on private property (except on single family houses, duplexes, or signage, but shall be allowed on industry standard billboards or large signs exceeding 600 sq. ft., in size), that provides sufficient elevation for the array's operation without the necessity of constructing a tower or other apparatus to extend the antenna array more than ten feet (10') above the structure. Installation on City property requires the execution of necessary agreements. However, if any tower exceeding the height limitation of the zoning district is needed to achieve the desired elevation, then a conditional use approval is required.

18. *Pole-Mounted Equipment.* All pole-mounted transmission equipment shall be mounted as close as technically possible to the pole so as to reduce the overall visual profile to the maximum extent feasible subject to applicable safety codes.

19. *Permit, License or Agreement.* For all WCFs to be located within the rights-of-way, prior to applying for an administrative approval, the applicant must have a valid permit, municipal agreement, license, Right-of-Way agreement, encroachment permit, or exemption otherwise granted by applicable law. Prior to the installation or construction of a WCF within the rights-of-way or a utility easement, the applicant or provider must notify all utilities located within such rights-of-

way or utility easement regarding the use of the rights-of-way or utility easement.

20. *Accessory Equipment.* In residential districts, within 200 feet of a residential district or the Greenway, all accessory equipment located at the base of a WCF shall be located or placed (at the applicant's choice) in an existing building, underground, or in an equipment shelter or cabinet that is (a) designed to blend in with existing surroundings, using architecturally compatible construction and colors; and (b) be located so as to be as unobtrusive as possible consistent with the proper functioning of the WCF.

21. *Site Design Flexibility.* Individual WCF sites vary in the location of adjacent buildings, existing trees, topography and other local variables. By mandating certain design standards, there may result a project that could have been less intrusive if the location of the various elements of the project could have been placed in more appropriate locations within a given site. Therefore, the WCF and supporting equipment shall be installed so as to best camouflage, disguise or conceal them, to make the WCF more closely compatible with and blend into the setting or host structure, upon approval by the City.

22. *Landscaping, Screening, Fencing, and Walls.*

(a) Equipment shelters and cabinets and other on the ground ancillary equipment (except for those in the public rights-of-way) shall be screened from view from adjacent rights-of-way, residential properties, commercial properties, the Greenway, parks and open space by landscaping, a site-obscuring fence or wall. Alternatively, where technically feasible, the applicant shall incorporate the cabinet and other equipment into the base of a new pole (for example, for a small wireless facility) provided there is adequate space in the right-of-way and that ADA sidewalk accessibility requirements can be met. All provisions of the ADA (including, but not limited to, clear space requirements) shall be met by the applicant.

(b) In particular, the ground level view of towers outside of the public-rights-of-way shall be mitigated by additional landscaping provisions as established through the administrative approval process.

(c) Except for locations in the rights-of-way, a site-obscuring fence or wall shall be constructed around each tower and around related support

or guy anchors at the height specified for the particular zoning district. Access shall only be through a locked gate. Fences and walls shall comply with applicable design standards of the Unified Development Code.

- (d) *New Poles.* To the extent technically feasible, new poles must be designed to match the existing light fixtures and other poles, and they shall serve a dual purpose (for example, a new light fixture, flag pole or banner clips).
23. *Additional Submittal Requirements for Towers.* At the time of filing an approval application for a tower, an applicant shall provide all of the following:
- (a) *Collocation Consent.* A written statement will be signed by a person with the legal authority to bind the applicant and the project owner, which indicates whether the applicant is willing to allow other transmission equipment owned by others to collocate with the proposed wireless communication facility whenever technically and economically feasible and aesthetically desirable.
- (b) *Design Justification.* A clear and complete written analysis that explains how the proposed design complies with the applicable design standards under this Section to the maximum extent feasible. A complete design justification must identify all applicable design standards under this Section and provide reasons why the proposed design either complies or cannot feasibly comply.
- (c) *Noise Study.* A noise study shall be required if the anticipated noise generated by the facility is expected to be at least 72 dBA or above the ambient (existing background) noise level, and the proposed site is in or within two hundred feet (200') of a residential district or the Greenway, for the proposed WCF and all associated equipment. The WCF shall not interfere with the peaceful and quiet enjoyment of the surrounding area and shall not create a nuisance to pedestrian or vehicular traffic.
- (d) *Additional Information Required.* Applicants for a conditional use approval for a tower shall also submit the following information:
- (1) A scaled site plan clearly indicating the location, type, height and width of the proposed tower, on-site land uses and zoning, adjacent land uses and zoning (including when adjacent to other municipalities or the County), separation distances, adjacent roadways, photo simulations, a depiction of all proposed transmission equipment, proposed means of access, setbacks from property lines, elevation drawings or renderings of the proposed tower and any other structures, topography, parking, utility runs and other information deemed by the City to be necessary to assess compliance with this Section.
- (2) Legal description of the parent tract and leased parcel (if applicable).
- (3) The setback distance between the proposed tower and the nearest residential unit and the nearest residentially zoned property.
- (4) A landscape plan showing specific landscape materials, if applicable.
- (5) Method of fencing, and finished color and, if applicable, the method of camouflage and illumination.
- (6) A certification of compliance with all applicable federal, state and local laws.
- (7) A description of the suitability of the use of existing towers or other structures to provide the services to be provided through the use of the proposed new tower.
- (8) A clear and complete written statement of purpose which shall minimally include: (1) a description of the objective to be achieved; (2) a to-scale map that identifies the proposed site location and the targeted service area to be benefited by the proposed project; and (3) full-color signal propagation maps with objective units of signal strength measurement that show the applicant's current service coverage levels from all adjacent sites without the proposed site, predicted service coverage levels from all adjacent sites with the proposed site, and predicted service coverage levels from the proposed site without all adjacent sites. These materials shall be reviewed and signed by a Wyoming-licensed professional engineer or a qualified employee of the applicant. The qualified employee of the applicant shall submit his or her qualifications with the application.

24. *Radio Frequency (RF) Emissions Compliance Report.* A written report will be prepared, signed, and sealed by a Wyoming-licensed professional engineer or a qualified employee of the applicant, which assesses whether the proposed WCF demonstrates compliance with the RF emissions limits established by the FCC. The qualified employee of the applicant shall submit his or her qualifications with the application.
25. *Noise.* In residential zone districts, or within two hundred feet (200') of a residential district or the Greenway, noise levels shall not exceed 55 dBA during daytime hours (7 a.m. to 10:30 p.m.) and 50 dBA during nighttime hours (10:30 p.m. to 7 a.m.) at a point measured horizontally from the tower, related appurtenances and related equipment cabinets. However, emergency backup power equipment may operate up to 72 dBA for up to 72 hours.
- g. ***Sharing of Towers and Collocation of Facilities.***
1. It is the policy of the City to minimize the number of wireless communication towers and to encourage the collocation of antenna arrays of more than one wireless communication service provider on a single tower.
 2. For macro cell towers seventy-five (75) feet and taller, no new macro cell tower may be constructed within one thousand (1,000) feet of an existing macro cell tower, unless it can be demonstrated an existing macro cell tower is not available or feasible for collocation of an additional wireless communication facility, or that its specific location does not satisfy the operational requirements of the applicant. For macro cell towers less than seventy-five (75) feet tall, no new macro cell tower may be constructed within five hundred (500) feet of an existing macro cell tower, unless it can be demonstrated an existing macro cell is not available or feasible for collocation of an additional wireless communication facility, or that its specific location does not satisfy the operational requirements of the applicant. Factors to be considered in determining whether an applicant has made this demonstration include those listed in the subsection 3. below.
 3. *Factors Considered in Granting Conditional Use Approvals for Towers.* In addition to any standards pursuant to the Unified Development Code, the Board shall consider the following factors in determining whether to recommend a conditional use approval, although the Board may waive or reduce the burden on the applicant of one or more of these criteria if the Board concludes that the goals of this Section are better served thereby.
 - (a) Towers exceeding a height of fifty (50) feet shall be able to accommodate collocation of one additional provider. Additional height to accommodate additional collocation may be approved if the applicant submits information certifying the tower has capacity for at least two (2) additional providers. The applicant shall provide a letter indicating its good faith intent to encourage collocation on the tower.
 - (b) Proximity of the tower to residential structures, residential districts, the Greenway and downtown area.
 - (c) Nature of uses on adjacent and nearby properties.
 - (d) Surrounding topography.
 - (e) Surrounding tree coverage and foliage.
 - (f) Design of the tower, with particular reference to design characteristics that have the effect of reducing or eliminating visual obtrusiveness.
 - (g) Proposed ingress and egress.
 - (h) No existing structures are located within the geographic area which meet applicant's engineering requirements.
 - (i) Existing towers or structures do not have sufficient structural strength to support applicant's proposed antenna and related equipment.
 - (j) The fees, costs, or contractual provisions required by the owner in order to share an existing tower or structure or to adapt an existing tower or structure for sharing are unreasonable. Costs exceeding new tower development are presumed to be unreasonable.
 - (k) The applicant demonstrates that there are other limiting factors not enumerated herein that render existing towers and structures unsuitable.
 - (l) Compliance with the requirements of Section 5.8.1.f (General Requirements).
 4. *Placement Provisions.* Macro cell towers that are proposed to be located in a residential district or within 200 feet of a residential district or the Greenway shall be subject to the siting priorities set forth for preferred tower locations in this Section.
- h. ***Setback Requirements.***
1. The tower structure shall be set back from property lines as required by that zone, master plan, if any, or a minimum of one foot (1') for every foot of tower height, whichever produces the greater setback, unless:
 - (a) The setback is waived by the owner of the

adjacent property and that waiver is accepted in conjunction with Administrative Review; or

- (b) The tower is constructed with breakpoint design technology. If the tower has been constructed using breakpoint design technology, the minimum setback distance shall be equal to one hundred ten percent (110%) of the distance from the top of the structure to the breakpoint level of the structure, or the applicable zone's minimum side setback requirements, whichever is greater. For example, on a 100-foot tall monopole with a breakpoint at eighty feet (80'), the minimum setback distance would be twenty-two feet (22') (110% of 20 feet, the distance from the top of the monopole to the breakpoint) or the minimum side yard setback requirements for that zone, whichever is greater. Provided, that if an applicant proposes to use breakpoint design technology to reduce the required setback from a residence, the issuance of a permit for the tower shall be conditioned upon approval of the tower design by a Wyoming licensed professional engineer; or
 - (c) The tower is a small wireless facility located within the right-of-way or within a setback adjacent to a right-of-way.
2. All equipment shelters, cabinets, or other on the ground ancillary equipment shall meet the setback requirement of the zone in which it is located.

i. Preferred Macro Cell Tower Locations.

- 1. All new macro cell towers proposed to be located in a residential district or within two hundred feet (200') of a residential district or the Greenway are permitted only after application of the following siting priorities, ordered from most-preferred to least-preferred:
 - (a) City-owned or operated property and facilities not in the residential district or near the Greenway and not including rights-of-way;
 - (b) industrial zones;
 - (c) commercial zones;
 - (d) other non-residential districts;
 - (e) City rights-of-way in residential districts;
 - (f) parcels of land in residential districts;
 - (g) designated historic structures or districts.
- 2. The applicant for a macro cell tower located in a residential district or within two hundred feet (200') of a residential district or the Greenway shall address these preferences in an alternative sites analysis prepared pursuant to the subsection j. below.

j. Submittal Requirements for Alternative Sites Analysis

- 1. For a macro cell tower in a residential district or within two hundred feet (200') of a residential district or the Greenway, the applicant must address the City's preferred tower locations with a detailed explanation justifying why a site of higher priority was not selected. The City's tower location preferences must be addressed in a clear and complete written alternative sites analysis that shows at least three (3) higher ranked, alternative sites considered that are in the geographic range of the service coverage objectives of the applicant, together with a factually detailed and meaningful comparative analysis between each alternative candidate and the proposed site that explains the substantive reasons why the applicant rejected the alternative candidate.
- 2. A complete alternative sites analysis provided under this subsection may include less than three (3) alternative sites so long as the applicant provides a factual written rationale for why it could not identify at least three (3) potentially available, higher ranked, alternative sites.
- 3. For purposes of disqualifying potential collocations or alternative sites for the failure to meet the applicant's service coverage or capacity objectives the applicant will provide (a) a description of its objective, whether it be to or address a deficiency in coverage or capacity (b) detailed maps or other exhibits with clear and concise RF data to illustrate that the objective is not met using the alternative (whether it be collocation or a more preferred location); and (c) a description of why the alternative (collocation or a more preferred location) does not meet the objective.

k. Exceptions to Standards.

- 1. *Applicability.* Except as otherwise provided in this Section (under Site Design Flexibility), no WCF shall be used or developed contrary to any applicable development standard unless an exception has been granted pursuant to this Section. These provisions apply exclusively to conditional use approvals and are in lieu of the generally applicable variance provisions in the Unified Development Code; provided this Section does not provide an exception from this Section's visual impact and stealth design.
- 2. *Procedure Type.* A WCF exception is subject to approval by the Board.
- 3. *Submittal Requirements.* An application for a wireless communication facility exception shall include:

- (a) A written statement demonstrating how the exception would meet the criteria.
- (b) A site plan that includes:
 - (1) Description of the proposed facility's design and dimensions, as it would appear with and without the exception.
 - (2) Elevations showing all components of the wireless communication facility, as it would appear with and without the exception.
 - (3) Color simulations of the wireless communication facility after construction demonstrating compatibility with the vicinity, as it would appear with and without the exception.
- 4. **Criteria.** An application for a wireless communication facility exception shall be granted if the following criteria are met:
 - (a) The exception is consistent with the purpose of the development standard for which the exception is sought.
 - (b) Based on a visual analysis, the design minimizes the visual impacts to residential districts or the Greenway through mitigating measures, including, but not limited to, building heights, bulk, color, and landscaping.
 - (c) The applicant demonstrates the following:
 - (1) The development standard materially limits or inhibits the ability of the applicant or provider to compete in a fair and balanced legal and regulatory environment;
 - (2) The situation can only be addressed through an exception to one or more of the standards in this Section; and
 - (3) The exception is narrowly tailored such that the wireless communication facility conforms to this Section's standards to the greatest extent possible.
- i. **Removal of Abandoned Wireless Communication Facilities.** Any wireless communication facility that is not operated for a continuous period of twelve (12) months shall be considered abandoned, and the owner of such WCF shall so notify the City in writing and remove the same within ninety (90) days of giving notice to the City of such abandonment. Failure to remove an abandoned WCF within said ninety (90) days shall be grounds to remove the WCF at the owner's expense, including all costs and reasonable attorneys' fees. Irrespective of any agreement between them to the contrary, the owner of such unused facility and the owner of a building or land upon which the WCF is located, shall be jointly and severally responsible for the removal of abandoned WCFs and the tower's foundation, if any. If there are two or more users of a single tower, then this provision shall not become effective until all users cease using the tower. A building demolition permit is required for a tower.
- m. **Independent Technical and Legal Review.** Although the City intends for City staff to review applications to the extent feasible, the City may retain the services of an independent technical expert and attorney of its choice to provide evaluations of permit applications for WCFs, when they are subject to conditional use approvals or Administrative Review. The third-party consultants shall have recognized qualifications in the field of wireless communication facilities. The expert's review may include, but is not limited to (a) the accuracy and completeness of the items submitted with the application; (b) the applicability of analysis and techniques and methodologies proposed by the applicant; (c) the validity of conclusions reached by the applicant; and (d) whether the proposed WCF complies with the applicable approval criteria set forth in this Section. The applicant shall pay the cost, not to exceed three thousand dollars (\$3,000) per application review, for any independent consultant fees through a deposit within ten (10) days of the City's request. When the City requests such payment, the application shall be deemed incomplete for purposes of application processing timelines until the deposit is received. In the event that such costs and fees do not exceed the deposit amount, the City shall refund any unused portion within thirty (30) days after the final permit is released or, if no final permit is released, within thirty (30) days after the City receives a written request from the applicant. If the costs and fees exceed the deposit amount, then the applicant shall pay the difference to the City before the permit is issued. The third party shall provide an itemized description of the services provided and related fees and charges.
- n. **Final Inspection.**
 - 1. A certificate of completion will only be granted upon satisfactory evidence that the WCF was installed in substantial compliance with the approved plans and photo simulations.
 - 2. If it is found that the WCF installation does not substantially comply with the approved plans and

photo simulations, the applicant shall make any and all such changes required to bring the WCF installation into compliance promptly.

o. Compliance.

1. All wireless communication facilities must comply with all standards and regulations of the FCC and any State or other federal government agency with the authority to regulate wireless communication facilities.
2. The site and wireless communication facilities, including all landscaping, fencing and related transmission equipment must be maintained at all times in a neat and clean manner and in accordance with all approved plans.
3. All graffiti on wireless communication facilities must be removed at the sole expense of the permittee after notification by the City to the owner/operator of the WCF.
4. If any FCC, State or other governmental license or any other governmental approval to provide communication services is ever revoked as to any site permitted or authorized by the City, the permittee must inform the City of the revocation within thirty (30) days of receiving notice of such revocation.

p. Indemnification. Each WCF located on City property shall be deemed to have as a condition of its approval a requirement that the applicant and provider defend, indemnify and hold harmless the City and its officers, agents, employees, volunteers, and contractors ("City Indemnitees") from any and all liability, damages, or charges (including attorneys' fees and expenses) arising out of claims, suits, demands, or causes of action as a result of the permit process, a granted permit, construction, location, performance, operation, maintenance, repair, installation, replacement, removal or restoration of the WCF; except no indemnity shall be required where the claim arises from the sole negligence or willful misconduct of the City.

q. Eligible Facilities Request.

1. *Purpose.* This Section implements Section 6409(a) of the Spectrum Act (47 U.S.C. Section 1455(a)), as interpreted by the FCC in its Report and Order No. 14-153 and Declaratory Ruling and Third Report and Order released September 27, 2018, which requires a state or local government to approve any Eligible Facilities Request for a modification of an existing tower or base station that does not result in a substantial change to the physical dimensions of such tower or base station.

2. Application Review.

- (a) *Application:* The City shall prepare and make publicly available an application form, the requirements for which shall be limited to the information necessary for the City to consider whether an application is an Eligible Facilities Request. The City may not require an applicant to submit any other documentation intended to illustrate the need for any such wireless facilities or to justify the business decision to modify such wireless facilities.
- (b) *Review:* Upon receipt of an application for an Eligible Facilities Request pursuant to this section, the City shall review such application, make its final decision to approve or disapprove the application, and advise the applicant in writing of its final decision.
- (c) *Timeframe for Review:* Within 60 days of the date on which an applicant submits an application seeking approval of an Eligible Facilities Request under this section, the City shall review and act upon the application, subject to the tolling provisions below.
- (d) *Tolling of the Timeframe for Review:* The 60-day review period begins to run when an application is filed and may be tolled only by mutual agreement between the City and the applicant, or in cases where the City determines that the application is incomplete.
 - (1) To toll the timeframe for incompleteness, the City must provide written notice to the applicant within 30 days of receipt of the application, specifically delineating all missing documents or information required in the application.
 - (2) The timeframe for review begins running again when the applicant makes a supplemental submission in response to the City's notice of incompleteness.
 - (3) Following a supplemental submission, the City will have 10 days to notify the applicant if the supplemental submission did not provide the information identified in the original notice delineating missing information. The timeframe is tolled in the case of second or subsequent notices pursuant to the procedures identified in this Section. Second or subsequent notices of incompleteness may not specify missing documents or information

that was not delineated in the original notice of incompleteness.

- (e) Failure to Act: In the event the City fails to approve or deny a complete application under this Section within the timeframe for review (accounting for any tolling), the request shall be deemed granted provided the applicant notifies the City in writing after the review period has expired.
- r. ***Small Wireless Facilities - Collocation on Existing Structures.***
1. *Purpose.* This section implements the 60-day shot clock which is contained in the FCC's Declaratory Ruling and Third Report and Order released September 27, 2018, regarding the collocation of small wireless facilities on existing structures.
 2. *Application Review.*
 - (a) Application: The City shall prepare and make publicly available an application form, which form shall be used by the applicant.
 - (b) Reset: Upon submission of an application for collocation of small wireless facilities on an existing structure pursuant to this section, the City shall have 10 days from the submission of the application to determine whether the application is incomplete. Once the applicant files a resubmittal, the shot clock shall then reset to a new 60-day period.
 - (c) Tolling of the Timeframe for Review: Following a supplemental submission, the City shall have 10 days to notify the applicant if the supplemental submission did not provide the information identified in the original notice delineating missing information. The timeframe is tolled in the case of second or subsequent notices. Second or subsequent notices of incompleteness may not specify missing documents or information that was not delineated in the original notice of incompleteness. Tolling may also occur by mutual agreement of the City and applicant.
 - (d) Failure to Act: In the event the City fails to approve or deny a complete application under this section within the timeframe for review, the applicant shall be entitled to pursue all remedies under applicable law.
- s. ***Small Wireless Facilities - Construction (New Structures).***
1. *Purpose.* This section implements the 90-day shot clock which is contained in the FCC's Declaratory Ruling and Third Report and Order released September 27, 2018, regarding the construction of small wireless facilities on a new structure.
2. *Application Review.*
- (a) Application: The City shall prepare and make publicly available an application form; which form shall be used by the applicant.
 - (b) Reset: Upon submission of an application for the construction of small wireless facilities on a new structure pursuant to this section, the City shall have 10 days from the submission of the application to determine whether the application is incomplete. Once the applicant files a resubmittal, the shot clock shall then reset to a new 90-day period.
 - (c) Tolling of the Timeframe for Review: Following a supplemental submission, the City shall have 10 days to notify the applicant if the supplemental submission did not provide the information identified in the original notice delineating missing information. The timeframe is tolled in the case of second or subsequent notices. Second or subsequent notices of incompleteness may not specify missing documents or information that was not delineated in the original notice of incompleteness. Tolling may also occur by mutual agreement of the City and applicant.
 - (d) Failure to Act: In the event the City fails to approve or deny a complete application under this section within the timeframe for review, the applicant shall be entitled to pursue all remedies under applicable law.
- t. ***Collocation Applications for Other than Small Wireless Facilities.***
1. *Purpose.* This Section implements, in part, 47 U.S.C. Section 332(c)(7) of the Federal Communications Act of 1934, as interpreted by the FCC in its Report and Order No. 14-153, and Declaratory Ruling and Third Report and Order released September 27, 2018.
 2. *Application Review.*
 - (a) Application: The City shall prepare and make publicly available an application form, the requirements of which shall be limited to the information necessary for the City to consider whether an application is a collocation request for other than small wireless facilities.
 - (b) Review: Upon receipt of an application for a request pursuant to this section, the City shall review such application, make its final decision to approve or disapprove the application, and advise

the applicant in writing of its final decision.

- (c) **Timeframe for Review:** Within 90 days of the date on which an applicant submits an application seeking approval of a request under this section, the City shall review and act upon the application, subject to the tolling provisions below.
- (d) **Tolling of the Timeframe for Review:** The 90-day review period begins to run when the application is filed and may be tolled only by mutual agreement between the City and the applicant, or in cases where the City determines that the application is incomplete.
 - (1) To toll the timeframe for incompleteness, the City must provide written notice to the applicant within 30 days of receipt of the application, specifically delineating all missing documents or information required in the application.
 - (2) The timeframe for review begins running again when the applicant makes a supplemental submission in response to the City's notice of incompleteness.
 - (3) Following a supplemental submission, the City will notify the applicant within 10 days if the supplemental submission did not provide the information identified in the original notice delineating missing information. The timeframe is tolled in the case of second or subsequent notices pursuant to the procedures identified in this section. Second or subsequent notices of incompleteness may not specify missing documents or information that was not delineated in the original notice of incompleteness.
- (e) **Failure to Act:** In the event the City fails to approve or deny a complete application under this section within the timeframe for review (accounting for any tolling), the applicant shall be entitled to pursue all remedies under applicable law.

u. ***New Site or Tower Applications.***

- 1. ***Purpose.*** This Section also implements, in part, 47 U.S.C. Section 332(c)(7) of the Federal Communications Act of 1934, as interpreted by the FCC in its Report and Order No. 14-153, and Declaratory Ruling and Third Report and Order released September 27, 2018.
- 2. ***Application Review.***
 - (a) **Application:** The City shall prepare and make publicly available an application form, the

requirements of which shall be limited to the information necessary for the City to consider whether an application is a request for a new site or tower.

- (b) **Review:** Upon receipt of an application for a request for a new site or tower pursuant to this section, the City shall review such application, make its final decision to approve or disapprove the application, and advise the applicant in writing of its final decision.
- (c) **Timeframe for Review:** Within 150 days of the date on which an applicant submits an application seeking approval of a request for a new site or tower under this section, the City shall review and act upon the application, subject to the tolling provisions below.
- (d) **Tolling of the Timeframe for Review:** The 150-day review period begins to run when the application is filed and may be tolled only by mutual agreement between the City and the applicant, or in cases where the City determines that the application is incomplete.
 - (1) To toll the timeframe for incompleteness, the City must provide written notice to the applicant within 30 days of receipt of the application, specifically delineating all missing documents or information required in the application.
 - (2) The timeframe for review begins running again when the applicant makes a supplemental submission in response to the City's notice of incompleteness.
 - (3) Following a supplemental submission, the City will notify the applicant within 10 days if the supplemental submission did not provide the information identified in the original notice delineating missing information. The timeframe is tolled in the case of second or subsequent notices pursuant to the procedures identified in this section. Second or subsequent notices of incompleteness may not specify missing documents or information that was not delineated in the original notice of incompleteness.
- (e) **Failure to Act:** In the event the City fails to approve or deny a complete application under this section within the timeframe for review (accounting for any tolling), the applicant shall be entitled to pursue all remedies under applicable law.

- v. **Multiple Sites in One Application.** An applicant may propose no more than ten (10) sites in a batched application. The denial of a site in a batched application shall not affect the approval of any remaining sites.
- w. **Application and Other Fees.** In connection with the filing of an application, the applicant shall pay all application and other fees according to the City’s fee schedule and federal law.
- x. **Laws, Rules and Regulations.** This Section shall be subject to all applicable laws, rules and regulations.
- y. **Severability.** The various parts, sentences, paragraphs, provisions and clauses of this Section are hereby declared to be severable. If any part, sentence, paragraph, provision or clause is adjudged unconstitutional or invalid by a court of competent jurisdiction, the remainder of this Section shall not be affected thereby.
- z. **Conflicts.** These Wireless Communication Facilities regulations are in addition to other regulations in the Unified Development Code. In case of a conflict between regulations, this Section shall control.

- 3. Each house placed in a park or portion of a park developed after the adoption of this code shall have a data plate affixed to it.
- 4. **Skirting.** All houses shall be skirted with a rigid material. Skirting shall be in place within 30 days after the house is set on the space. Skirting shall provide entry access.
- 5. **Utilities.** All spaces in the park shall be provided with utilities meeting standards specified by City, board of public utilities and state regulations and inspected for compliance with those regulations. Each house shall be properly connected to those utilities.
- 6. **Common Storage Areas.** Areas within the park for the storage of boats, trailers, campers and recreational vehicles shall be provided. They shall be screened from adjacent residential properties.
- 7. **Dimensional Standards.** All parks and spaces within parks shall meet the following dimensional standards. Each unit space within the park shall have its boundaries clearly delineated. Accessory structures excluding carports, or any other structure that is open on two or more sides, shall meet these standards.

5.8.2 Manufactured Homes and Parks

- a. **Generally.** Housing that meets the definition of a manufactured home shall be permitted in any residential district provided it meets the specific standards of this section, the standards for that district and all other applicable construction standards.
- b. **General Standards.** Manufactured housing parks shall be permitted only as a use requiring public hearing in any residential district or as a planned unit development, and shall meet all other applicable requirements of the zoning district.
 - 1. Any property to be used as a manufactured housing park shall comply with the minimum standards governing the parks as adopted and maintained by the Department of Public Health for the state of Wyoming and only after certification of compliance and a permit have been duly issued.
 - 2. Any property to be developed as a manufactured housing park shall be platted as required by the subdivision regulations for the City.

<i>Dimension</i>	<i>Minimum Requirement</i>	
<i>Minimum Total Area</i>	5 acres	
<i>Park Density</i>	9 units per acre for units up to 750 square feet; 7 units per acre for units over 750 square feet	
<i>Lot space area per dwelling unit</i>	3,000 square feet	
<i>Lot frontage per dwelling unit (frontage)</i>	32'	
<i>Setbacks*</i>	<i>Front</i>	10'
	<i>Side</i>	15' on main entry side; 20' total both sides (may be allocated to one side for zero-lot line lots)
	<i>Public Street</i>	25'
	<i>Other Dwelling</i>	20'

* In instances where the zoning district setback requirements are more restrictive, the district standards shall be used as the minimum setbacks from all property lines.

- c. **Roadway Standards.** Park roadways shall be paved and meet the following dimensional standards:

Roadway Type*	Minimum Requirement
One-way streets	38' roadways 28' of pavement
Cul de sacs	400' maximum length from start to center point of turning circle 35' roadway 25' pavement
Other Roadways	40 feet roadways 32 feet pavement

* Any street that connects two public streets shall be built to the standards of Article 4, Section 4.3.

- d. **Walkways, lighting and parking standards.**

1. Walkways. All houses shall be connected to the adjacent park roadway via a hard-surfaced walkway. The vehicle parking pad may be used as a portion of this walkway. Hard-surfaced walkways shall be provided within the park roadway as follows:
 - (a) Minor park roadways (roadways serving 25 units or less) shall have a walkway on at least one side of the park roadway.
 - (b) Major park roadways (roadways serving more than 25 units) shall have a walkway on both sides of the park roadway.
2. Lighting. All park roadways and walkways shall be adequately lit to provide for the safety of park residents.
3. Parking. Two off-street parking stalls shall be provided per unit space.

- e. **Recreation Space.** For the purposes of this section, "recreation space" is defined as an area of land that is available to park residents for recreational activities. It does not include roadways, storage areas or yards. For parks with more than 25 spaces, or additions to those parks, recreation space shall be provided as follows:

Average Lot Size	Required Recreation Space
3000 to 3,999 square feet	8% of gross park area
4,000 to 4,999 square feet	4% of gross park area
5,000 square feet or more	No requirement

- f. **Existing Manufactured Home and Manufactured Home Parks.** An existing house or park that does not meet the definition of a manufactured home or park as outlined in this Title shall be deemed to be a nonconforming use without regard to the standards of the district in which it is located. The nonconforming use may be continued provided that the continued use does not constitute a hazard to health and is not a public nuisance. The nonconforming use shall not be extended, enlarged, or changed unless the entire home or park is brought into compliance with current regulations for manufactured homes or new manufactured home parks. For a manufactured home park, the procedures shall be the same as those for establishing a manufactured home park in that district. In addition to the information and application for the district, the request shall also contain the following information:

1. A draft written agreement from the applicant to insure that the improvements to the new area and the improvements to the existing area will be provided;
2. A specific time schedule for all the improvements;
3. A specific list of exceptions to the standards for new parks that cannot or will not be met when all improvements specified in the agreement are provided.

Expansion of the park and the installation of improvements will not be initiated until the agreement and the other requirements of the district have been approved.

- g. **Travel Trailers and Recreational Vehicles.** Travel trailers and recreational vehicles shall not be installed in manufactured housing parks or subdivisions as a dwelling unit. The use of travel trailers and recreational vehicles shall be allowed only in campgrounds, mobile home parks or combined parks as defined in the state of Wyoming Mobile Home Park and Campground regulations.

- h. **Manufactured Homes on Single Platted Properties or Tracts.** Manufactured homes are permitted on any platted residential property or tract subject to the provisions of this section. This section does not apply to homes placed in manufactured home parks. Homes to be placed on a property or tract shall meet the following requirements:
 1. The home shall be sited in such a fashion that it meets all the requirements of the district in which it is located.
 2. The home shall have the delivery system removed. The home shall be installed on a permanent foundation constructed of masonry, concrete or other approved material and shall comply with the building code. The

foundation system shall be designed and constructed to sustain, within the stress limitations specified in the building code, all loads specified in the building code. The installation instructions as provided by the manufacturer of the manufactured home shall be used to determine permissible points of support for vertical loads and points of attachment for anchorage systems used to resist horizontal and uplift forces. The foundation system design shall be stamped and signed by a Wyoming licensed professional engineer.

3. The house shall be built to the current HUD code for this zone as referenced in the federal manufactured housing construction and safety standards. Skirting and permanent perimeter enclosures shall be installed. Skirting shall be of material suitable for exterior exposure and contact with the ground. Permanent perimeter enclosures shall be constructed of materials as required by the building code for regular foundation construction. Skirting shall be installed in accordance with the skirting manufacturer's installation instructions. Skirting shall be adequately secured to assure stability, to minimize vibration and susceptibility to wind damage, and to compensate for possible frost heave.
4. Where retaining walls are used as a permanent perimeter enclosure, they shall resist the lateral displacements of soil or other materials and shall conform to the building code as specified for foundation walls. Retaining walls and foundation walls shall be constructed of approved treated wood, concrete, masonry or other approved materials or combination of materials as for foundations as specified in the building code. Siding materials shall extend below the top of the exterior of the retaining or foundation wall or the joint between siding and enclosure wall shall be flashed in accordance with the building code.
5. The structure shall have a pitched roof, with a slope of not less than a nominal three inch vertical rise for each twelve (12) inches of horizontal run. Roof material shall consist of nonreflective material customarily used for conventional dwellings including but not limited to fiberglass shingles, composition shingles or tile material. Roof materials shall not include flat or corrugated sheet metal, except for manufactured metal roof panels.
6. The structure shall have a roof overhang of not less than eight inches measured from the vertical side of the home.
7. The structure shall have siding material consisting of wood or wood products, stucco, brick, rock, horizontal lap steel or aluminum or horizontal lap vinyl.
8. The structure shall be a minimum of 24' along the widest part of the structure's shortest axis.
9. The structure shall be constructed in accordance with the most recent version of the HUD code. However, no home will be permitted under this section if it was built prior to the year 2000.

5.8.3 Drive-through Facilities

Where any use provides drive-through facilities as an element of the site and building design, the following specific conditions shall apply.

- a. **Queuing Area.** Sufficient dedicated queuing areas shall be provided for vehicles awaiting service.
 - (1) A minimum queuing area of 60 feet shall be provided at each service area where a vehicle may stop. A lesser queuing area may be approved by the Director. The Director may require a transportation analysis or study to make this determination.
 - (2) Minimum required queuing areas shall not intersect with any required pedestrian connection on the lot or in the public right-of-way.
 - (3) Queuing areas and service areas or facilities shall be setback at least 30 feet from any right-of-way line.
- b. **Residential Buffers.** Any service area or facility shall be oriented away from and fully screened from any property that is residentially zoned or used solely for residential purposes. No speaker, sign, or service window shall be audible or visible from any property zoned for or used solely for residential purposes. All elements of the drive-through within 100 feet of residentially zoned property shall require a Level 3 landscape buffer according to Section 6.3. All elements of a drive-through 100 feet or more from residentially zoned property, but on lots abutting residentially zoned property shall require a Level 2 landscape buffer according to Section 6.3. Alternative buffers may be approved by the Director as specified in Section 6.3.
- c. **Pedestrian-Area Limitations.** In the NB, CBD, MUR, MUB, or any situation where the Small-scale Commercial and Mixed-use Design Standards in Section 6.7 apply, any drive through facility shall meet the following additional standards.
 - (1) No more than 2 drive-through facilities may be located on a single block, except that where block orientation, lot arrangements and site designs allow all drive-

through facilities to be separated by at least 250', more than 2 may be permitted.

- (2) Any use providing drive-through services shall also provide at least one pedestrian walk-up service area, or some other additional pedestrian amenity or facility. Exterior pedestrian service windows, vestibules, or buildings with internal service areas frequented by pedestrians may count towards this requirement.

5.8.4 Fences

a. **Design Standards.** Within all residential zoning districts (AR, LR, MR, HR, NR-1, NR-2, NR-3, MUB, MUR, MUE), residential uses within non-residential zone districts, and the CBD District:

- 1. Fences are limited to a maximum of four (4) feet in height in any front yard setback. The front yard setback is defined as the area between the front property line and the front building line of the principal building.
- 2. Fences may be a maximum of six (6) feet in height behind the front building line of the principal building.
- 3. The height of the fence is measured from the top of the fence to the finished grade of the lot directly under the fence or wall as such grade existed at the time the fence or wall was constructed. Any berm, wall or similar feature that is constructed for the purpose of increasing the height of a fence or wall shall be considered to be a part of the fence or wall. When a fence or wall is located on sloping ground constructed perpendicular to the slope and not parallel to the slope, the height shall be measured at the mid-point of each fence section.

- 4. Materials.
 - (a) Fencing within residential zone districts shall be constructed of brick, stone, wood, vinyl, wrought iron, concrete block, or chain link.
 - (b) Alternative materials, as approved by the Board of Adjustment through the Conditional Use process, may be allowed.
- 5. Exceptions.
 - (a) Fences may be constructed above seven feet for recreational uses including tennis courts, volleyball courts, swimming pools, golf driving ranges, goals and backstops, and similar uses. These fences shall conform to all other setbacks in the district.
 - (b) Fences may be constructed above four (4) feet in height, but no more than six (6) feet in height, for the purpose of screening utilities and mechanical systems.

- b. **Other Restrictions.** Applies to all zone districts.
- 1. Fences shall not be allowed within any right-of-way, unless specific "written" approval is given by the City Engineer.
 - 2. Fences shall not be constructed within any applicable sight triangle or vision clearance established in these regulations.
 - 3. No fence shall be constructed which hinders or obstructs access to any fire hydrant or is within a 3' radius of any fire hydrant.
 - 4. No fence shall be constructed within 2' of any public sidewalk or Greenway.

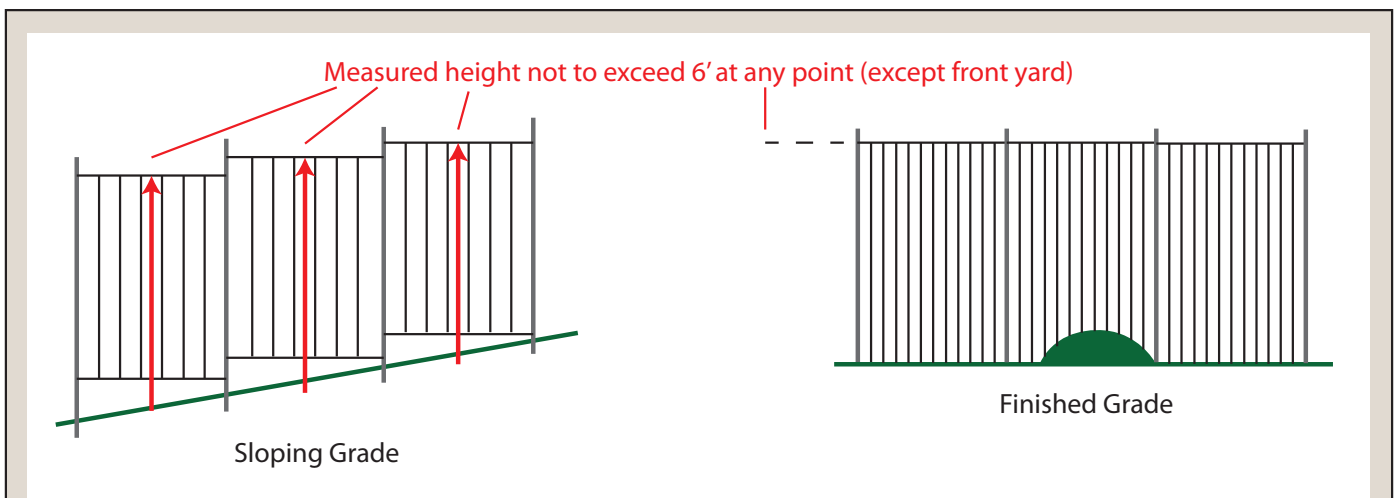

Figure 5-1: Fence Measurement

5.8.5 Refuse Containers

In addition to any other applicable site design standards in Article 6, all trash containers shall be placed behind the building setback line from all streets, and screened with solid material from view from all streets. All uses shall be required to provide trash containment consistent with these requirements except for detached, semi-attached and attached dwelling which have only the following limitations:

- a. Containers may not be stored in the public right of way associated with a public street and no case stored within 10' of any public sidewalk.
- b. The storage area shall be partially screened from view from the public right of way with vegetation or fencing that is compliant with fencing limitations.
- c. Storage does not include times when a refuse container is moved to the curb area for scheduled collections. This time frame shall not exceed 48 consecutive hours.

5.8.6 Outdoor Storage

Where Outdoor Storage is allowed, the storage area shall be screened from all adjacent streets with a Level 3 buffer as described in Section 6.3.5, Table 6-11. Where Outdoor Storage is allowed in the BP zone district, the storage area shall be screened from all adjacent streets with a 6' wall or solid fence (a landscape buffer is not required).

5.8.7 Oil and Gas Support Services

An entity wishing to provide oil and gas support services, including land uses which provide support service for oil and gas drilling operations such as parking and storage of exploration, production or workover equipment, pipe and production equipment, equipment and storage yards for road and pipeline construction contractors and production unit setup, may request a Special Use Approval from the Governing Body to temporarily defer all or a portion of the development requirements in the Cheyenne City Code, including landscaping requirements, right of way improvements, parking lot surface paving, and connection to City water or sewer. A Special Use Permit is only available for property within the Heavy Industrial -HI Zone District. Property proposed for the oil and gas support service option shall submit an application in accordance with the Special Use Approval as described in Article 2.

- a. **Requirements.** A site approved for a Special Use Permit shall be subject to the following requirements:
 1. No permanent facilities, including uses that would require restrooms, may be located on the site at the time of application or after approval.
 2. Outdoor storage of all materials stored, or to be stored, shall be screened from the view of the adjacent public right-of-way and adjacent properties.
 3. Screening shall be accomplished through the use of a solid fence or wall or through the use of landscape ing (including plant materials and/or berms) that provides year-round screening, or through a combination of fencing, walls and landscaping. Any landscaping shall meet appropriate maintenance standards.
 4. No maintenance activities shall be permitted. Maintenance is defined as any activity related to upkeep of vehicles or equipment that has a potential of causing the discharge of chemicals, lubricants, or other hazardous substances onto the ground.
- b. **Effect of Decision.** The construction of any permanent facilities on a Special Use Permit site shall invalidate the Special Use Permit, and the applicant shall be required to improve the site according to City Code. Approval of the application shall be valid for up to 18 months, with a 6 month extension available by written request to the Director prior to the end of the initial period. In no event shall the Special Use Permit be valid more than 2 years. At the conclusion of the special Use Permit period, the applicant shall either implement the approved site plan or vacate the premises in accordance with the Special Use Permit.
- c. **Submittal.** In addition to the requirement described for a special use approval in Article 2, applicants for a Special Use Permit for Oil and Gas Support Services shall submit the following for review and approval:
 1. A site plan depicting all currently required standards and including traffic and drainage studies as required, including but not limited to landscaping, right-of-way improvements and screening. The site plan shall identify all site improvements that the applicant seeks to defer under the Special Use Permit.
 2. An application for a Special Use Permit, Oil and Gas Support Services.
 3. A bond or other financial security to guarantee restoration of the site to its original condition following the expiration of the Special Use Permit, if required by the City Engineer.

5.8.8 Accessory Buildings

Accessory buildings associated with residential uses shall meet the following standards:

- a. There shall be a principal building constructed on the site prior to an accessory building being permitted.
- b. For double frontage, triple frontage and corner lots, the setback for a wall with vehicular access parallel to the adjacent right-of-way shall be 25'; otherwise the setback for double frontage, triple frontage and corner lots shall be half of the required principal building's front setback.
- c. Accessory buildings under 200 sq. ft. shall be allowed a side and rear setback of 0-feet.
- d. An accessory building shall not encroach on any recorded easement.
- e. Up to two accessory buildings shall be allowed per lot.
- f. The maximum total building footprint of all accessory buildings shall be equal to or less than 15% of the property area.
- g. Accessory Buildings shall not have a larger building footprint than the principal buildings enclosed footprint (porches and decks do not count toward the principal buildings footprint).
- h. Exceptions to accessory building height, area, and number may be approved by conditional use approval pursuant to UDC 2.2.4.
- i. The provisions of subsections (a), (b), (e), (f), and (g) of this section do not apply to accessory buildings approved in conjunction with a site plan.
- j. To be considered a separate building, the structures must not share any structural attachment and no part of either building may be within 3' of the other when viewed from plan view. Two structures closer than 3' or with a structural attachment shall be considered one building for the purposes of setback, area, and number.

This page is intentionally left blank.